

HIGH VOLTAGE MONOLITHIC IC

ECN3294TF

8-channel High Voltage analog switch IC

ECN3294 is an eight-channel High Voltage analog switching IC with bleed resistors on which latch-up free is realized by dielectric isolation technology.

High voltage and low ON-resistance MOS switches are used as output devices controlled by 3.3V or 5V signal. The ECN3294 is most suited to Ultrasound Imaging applications.

Functions

- High voltage and low on-resistance MOS switches integrated.
- One bleed resistor is built into each switch.
- 8bit shift register integrated.

Features

- Switch on-resistance: 19 Ω typ. ($V_{PP}=100V, V_{NN}=-100V, I_{SIG}=5mA, 250C$)
- Switch breakdown voltage: 220V
- Latch-up free CMOS and High-Voltage drive circuit.
- Power on/off sequence of power supply is free.
- The bleed resistance is 17.5k Ω . The customer can arbitrarily select the method of connecting resistance.
- ROHS Compliant

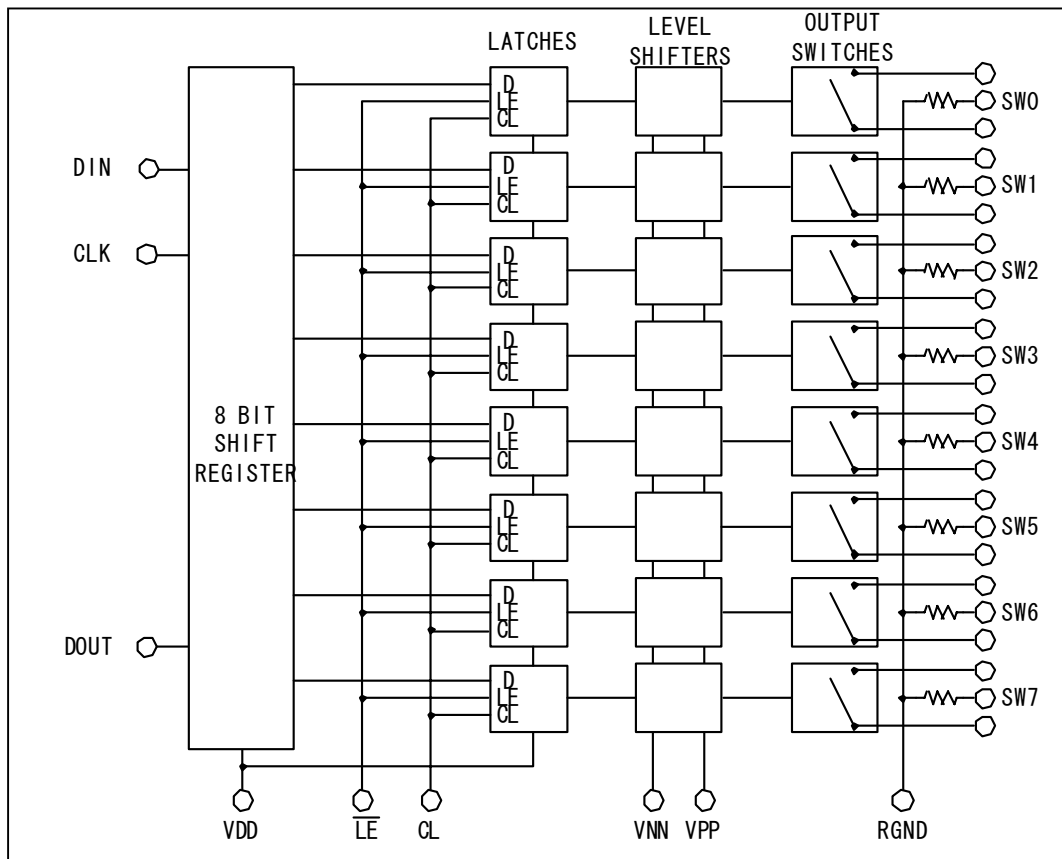

Fig.1 Block diagram

ECN3294TF

1. General

This Specification shall be applied to the following semiconductor integrated circuit.

- 1) Parts name : ECN3294TF
- 2) Application : Ultrasound imaging scanner and others
- 3) Structure : Monolithic IC
- 4) Package : TQFP48

2. Absolute Maximum Ratings

Table 1 Absolute Maximum Ratings

No.	Items	Symbol	Terminal	Values	Unit	Note
1	Logic power supply voltage	VDD	VDD	-0.5 ~ +7V	V	Ta=25°C
2	VPP-VNN supply voltage	-	VPP, VNN	220V	V	Ta=25°C
3	VPP Positive high voltage supply	VPP	VPP	-0.5 to VNN+200V	V	Ta=25°C
4	VNN negative high voltage supply	VNN	VNN	+0.5 to -200V	V	Ta=25°C
5	Logic input voltages	VDD	DIN, CLK, CL, LE	-0.5 to VDD+0.3	V	Ta=25°C
6	Analog signal range	-	SW0 to SW7	VNN to VPP	V	Ta=25°C
7	Bleed Resistor input voltages	-	BR0 to BR7	VNN to VPP	V	Pulse signal
8	Operating junction temperature	Tjop	-	-20 to +125	°C	
9	Storage temperature	Tstg	-	-65 to +150	°C	
10	Power dissipation	Pw	-	1.0	W	TQFP48 Ta=70°C

ECN3294TF

3. Electrical Characteristics

3.1 DC Characteristics

Table 2 DC Characteristics

Ta=25°C, VDD=5V

No.	Items	Symbol	Spec			Unit	Test conditions	
			Min	Typ	Max			
1	Small signal switch on resistance	RONS	-	24	38	Ω	I SIG=5mA	VPP=40V, VNN=-160V
			-	17	27		I SIG=200mA	
			-	19	27		I SIG=5mA	VPP=100V, VNN=-100V
			-	15	24		I SIG=200mA	
			-	19	25		I SIG=5mA	VPP=160V, VNN=-40V
			-	15	25		I SIG=200mA	
2	Small signal switch on resistance matching	ΔRONS	-	5	20	%	VPP=100V, VNN=-100V ISW=5mA	
3	Large signal switch on resistance	RONL	-	16	-	Ω	VPP=100V VNN=-100V	I SIG=1A
4	Value of output bleed resistance	RINT	10	17.5	25	kΩ	BR terminal to RGND IRINT=0.5mA	
5	Switch off leakage per switch	ISOL	-	1.0	10	μA	VSIG=VPP-10V, or VNN+10V	
6	DC offset switch (off)	DCOFF	-	10	100	mV	RL=100kΩ	
7	DC offset switch (on)	DCON	-	10	100	mV	RL=100kΩ	
8	Positive HV supply current	IPPQ1	-	10	50	μA	All SWs off	
9	Negative HV supply current	INNQ1	-	-10	-50	μA	All SWs off	
10	Positive HV supply current	IPPQ2	-	10	50	μA	All SWs on, ISW=5mA	
11	Negative HV supply current	INNQ2	-	-10	-50	μA	All SWs on, ISW=5mA	
12	IPP Supply current	IPP	-	-	7.0	mA	VPP=40V VNN=-160V	50kHz output switching frequency without load
			-	-	5.0		VPP=100V VNN=-100V	
			-	-	5.0		VPP=160V VNN=-40V	
13	INN Supply current	INN	-	-	7.0	mA	VPP=40V VNN=-160V	50kHz output switching frequency without load
			-	-	5.0		VPP=100V VNN=-100V	
			-	-	5.0		VPP=160V VNN=-40V	
14	Logic supply average current	IDD	-	-	4.0	mA	fCLK=5MHz, VDD=5.0V	
15	Logic supply quiescent current	IDDQ	-	-	10	μA		
16	Data out source current	ISOR	0.45	0.70	-	mA	VOUT=VDD-0.7V	
17	Data out sink current	ISINK	0.45	0.70	-	mA	VOUT=0.7V	

ECN3294TF

3.2 AC Characteristics

Table 3 AC Characteristics

Ta=25°C, VDD=5V

No.	Items	Symbol	Spec			Unit	Test conditions
			Min	Typ	Max		
1	SW Turn on time	tON	-	-	5.0	μs	VSIG=VPP-10V, RL=10kΩ
2	SW Turn off time	tOFF	-	-	5.0	μs	VSIG=VPP-10V, RL=10kΩ
3	Clock frequency	fCLK	-	-	20	MHz	50% duty cycle, fData=fCLK/2 VDD=3.0V or 5.0V
4	Clock delay time to data out	tDO	30	-	110	ns	DOUT terminal, VDD=3.0V
			20	-	70	ns	DOUT terminal, VDD=5.0V
5	Output voltage spike	+VSPK	-	-	150	mV	VPP=40V, VNN=-160V, RL=50Ω
		-VSPK	-	-	-200		
		+VSPK	-	-	150		VPP=100V, VNN=-100V, RL=50Ω
		-VSPK	-	-	-200		
		+VSPK	-	-	150		VPP=160V, VNN=-40V, RL=50Ω
		-VSPK	-	-	-200		

Table 4 AC Characteristics (for reference purpose only)

Ta=25°C, VDD=5V

No.	Items	Symbol	Spec			Unit	Condition
			Min	Typ	Max		
1	Off capacitance SW to GND	CSG (off)	-	9	-	pF	0V, 1MHz
2	On Capacitance SW to GND	CSG (on)	-	14	-	pF	0V, 1MHz
3	SW off isolation	KO	-30	-33	-	dB	f=5MHz, 1kΩ//15pF load
			-54	-60	-	dB	f=5MHz, 50Ω load
4	SW Crosstalk	KCR	-54	-60	-	dB	f=5MHz, 50Ω load

Note: These items are not tested when shipped.

ECN3294TF

4. Recommended Operating Conditions

Please operate in use within the limit of recommended operating conditions detailed in Table 5.

Table 5 Recommended Operating Conditions

No	Items	Symbol	Recommended Value
1	Logic power supply voltage	VDD	3.0V to 5.5V
2	Positive high voltage supply	VPP	40V to VNN+200V
3	Negative high voltage supply	VNN	-40V to -160V
4	High-level input voltage	VIH	0.9VDD to VDD
5	Low-level input voltage	VIL	0V to 0.1VDD
6	Analog signal voltage peak to peak	VSIG	VNN+10V to VPP-10V
7	Operating free air-temperature	Ta	0°C to 70°C
8	Switching frequency	Fsw	50kHz max, Duty Cycle=50%
9	Set up time for LE	TSD	Min.75ns
10	Pulse width of LE	TWLE	Min.75ns
11	Time width of CL	TWCL	Min.60ns
12	Set up time DATA to Clock	TSU	Min.10ns
13	Hold time DATA from Clock	Th	Min.20ns
14	Maximum VSIG Slew Rate	dV/dt	Max.30V/ns

Attention ;

- 1) Power on/off sequence of power supply is arbitrary except GND terminal of IC must be powered-up first and powered-down last.
- 2) It is indispensable to make there are not to exceed a maximum rated voltage by the occurrence of the excessive voltage in case of investing and cutting of the power supply.

ECN3294TF

5. Test Circuit

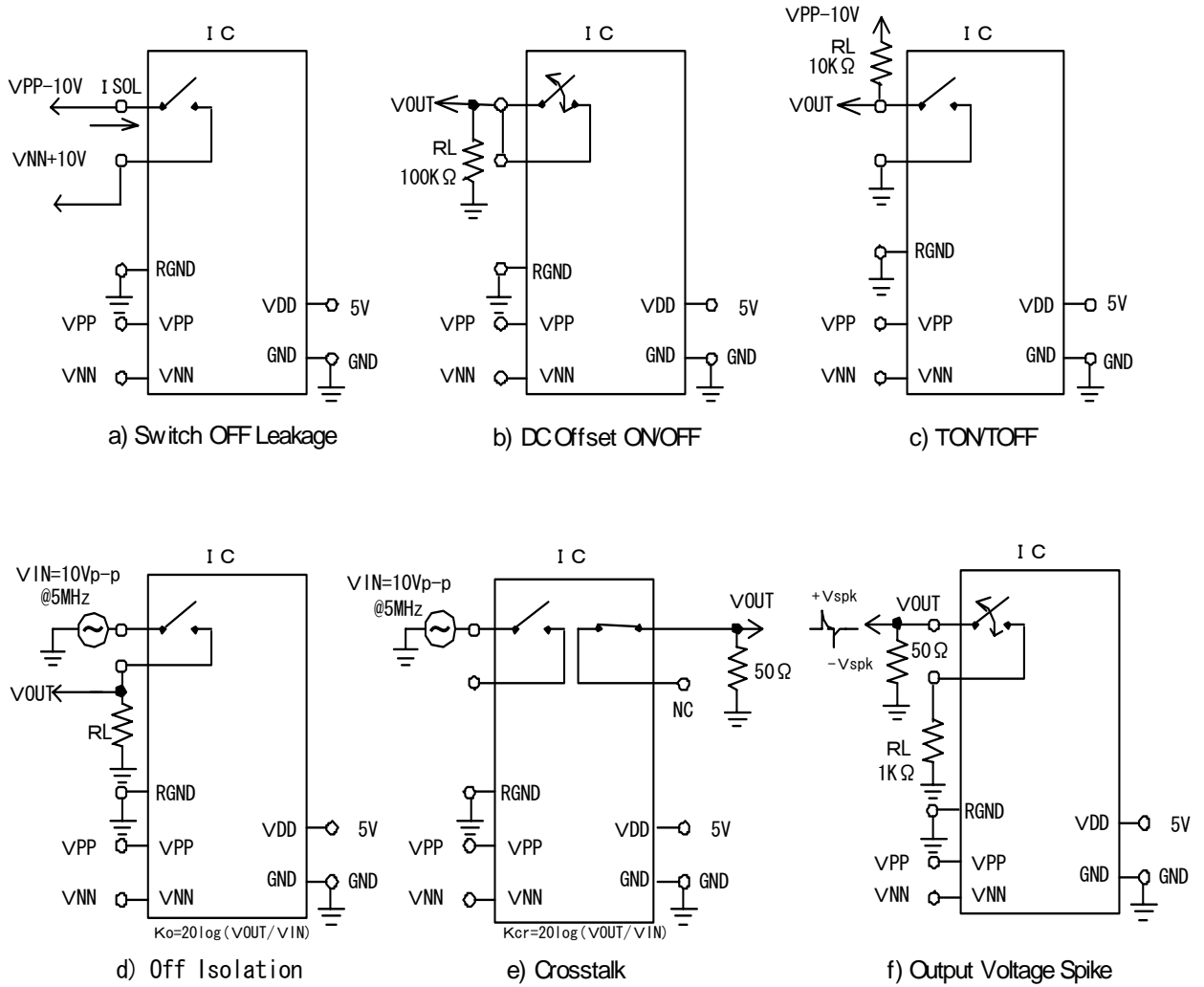

Note : The bleed resistor is assumed to be a condition not connected. The terminal BR (BR0-BR7) is assumed to be open.

Fig. 2 Test Circuit

ECN3294TF

6. Timing Waveforms

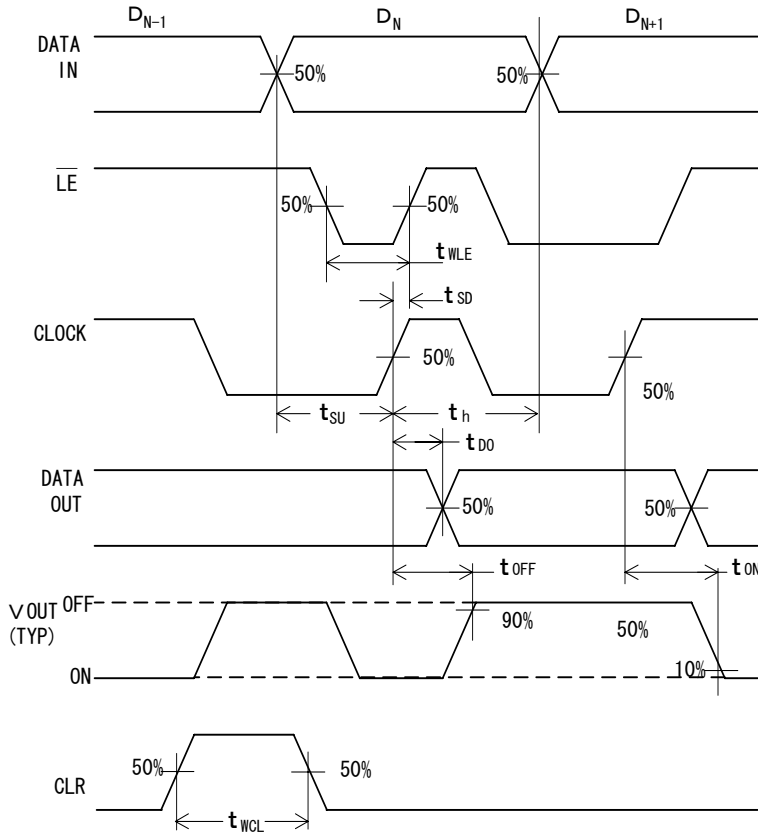

Fig. 3 Timing Waveforms

7. Truth Table

Table 6 Truth table

D0	D1	D2	D3	D4	D5	D6	D7	LE	CL	SW0	SW1	SW2	SW3	SW4	SW5	SW6	SW7
L								L	L	OFF							
H								L	L	ON							
	L							L	L		OFF						
	H							L	L		ON						
		L						L	L			OFF					
		H						L	L			ON					
			L					L	L				OFF				
			H					L	L				ON				
				L				L	L					OFF			
				H				L	L					ON			
					L			L	L							OFF	
					H			L	L							ON	
						L		L	L								OFF
						H		L	L								ON
X	X	X	X	X	X	X	X	H	L	Hold previous state							
X	X	X	X	X	X	X	X	X	H	OFF	OFF	OFF	OFF	OFF	OFF	OFF	OFF

ECN3294TF

8. Pin Configuration

ECN3294TF TQFP48 (48Pin TQFP)

Table3. Pin Configuration

Pin	Functions	Pin	Functions
1	SW5	25	VNN
2	N/C	26	N/C
3	SW4	27	RGND
4	BR4	28	GND
5	SW4	29	VDD
6	N/C	30	N/C
7	N/C	31	N/C
8	SW3	32	N/C
9	BR3	33	DIN
10	SW3	34	CLK
11	N/C	35	\overline{LE}
12	SW2	36	CLR
13	BR2	37	DOUT
14	SW2	38	N/C
15	N/C	39	SW7
16	SW1	40	BR7
17	BR1	41	SW7
18	SW1	42	N/C
19	N/C	43	SW6
20	SW0	44	BR6
21	BR0	45	SW6
22	SW0	46	N/C
23	N/C	47	SW5
24	VPP	48	BR5

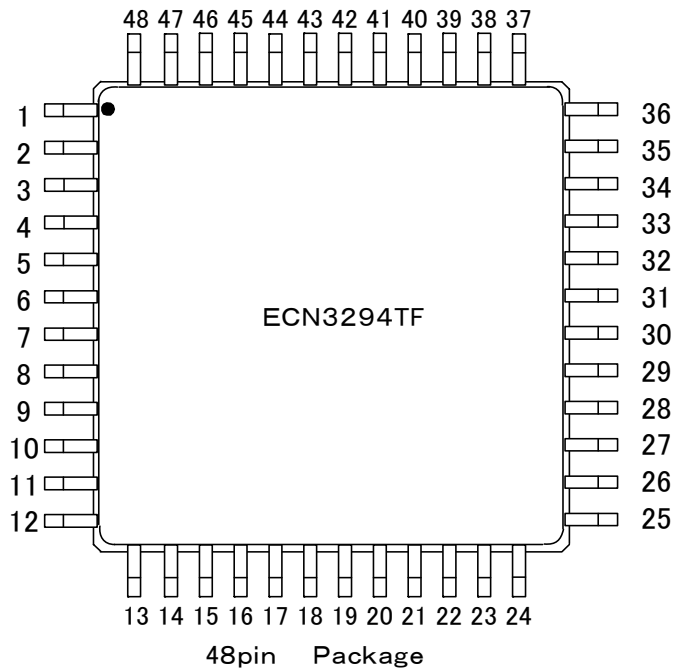

ECN3294TF

9. Package Outline

Units : mm

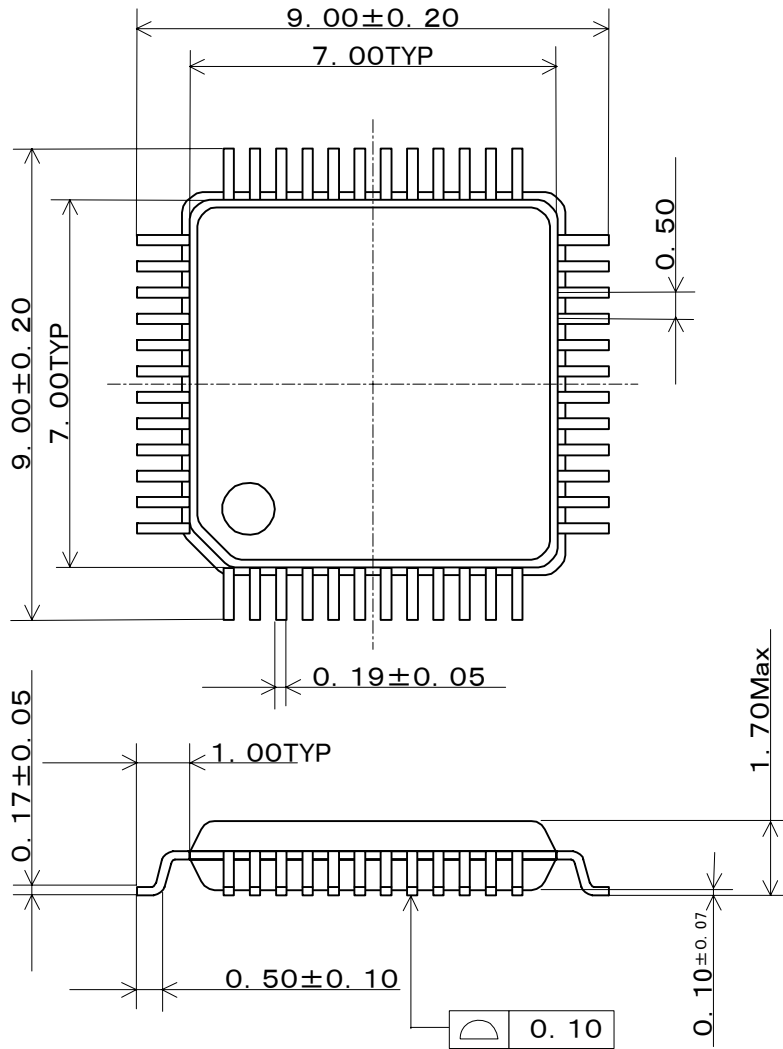

ECN3294TF

10. Marking spec

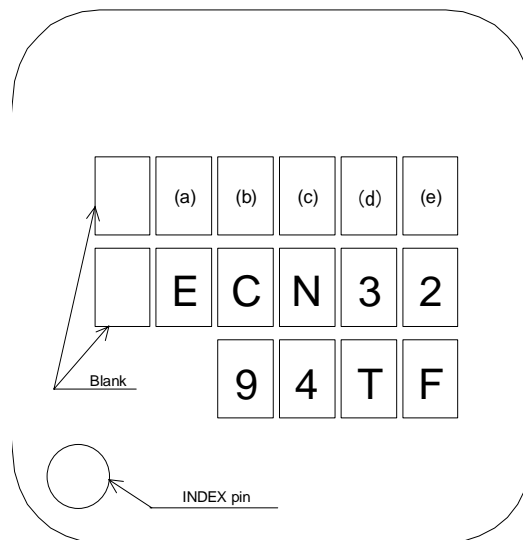

Lot numbering rule

(a) :Year code (Least significant digit of Assembled year (A.D.))

(b) :Month code (Refer to following table.)

Month	1	2	3	4	5	6	7	8	9	10	11	12
Month code	A	B	C	D	E	K	L	M	N	X	Y	Z

(c),(d),(e) :Serial number within year/month code

ECN3294TF

11. Packing Form

Packaging details are as shown below.

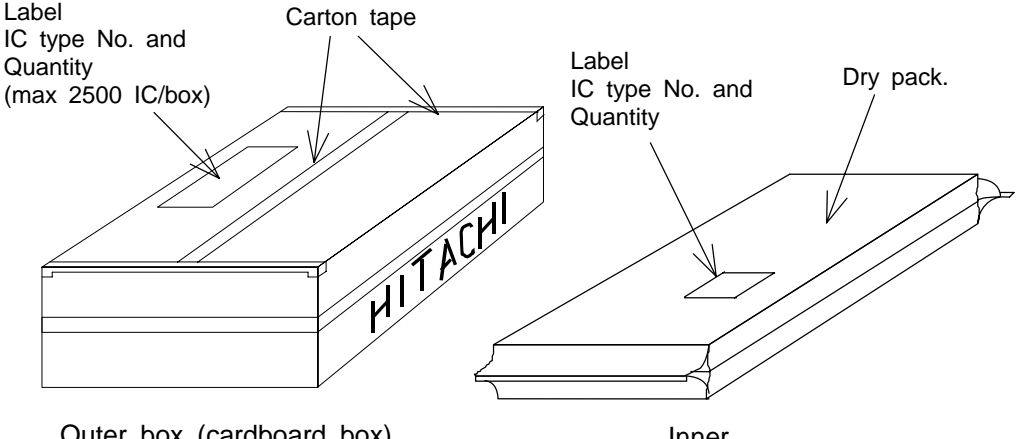
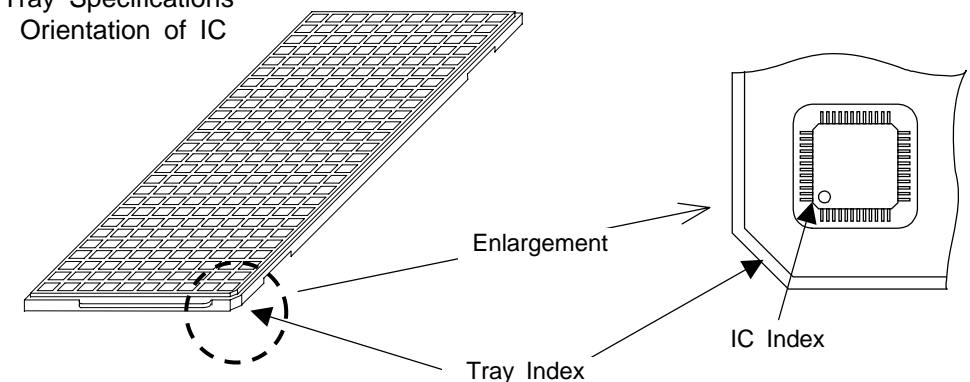
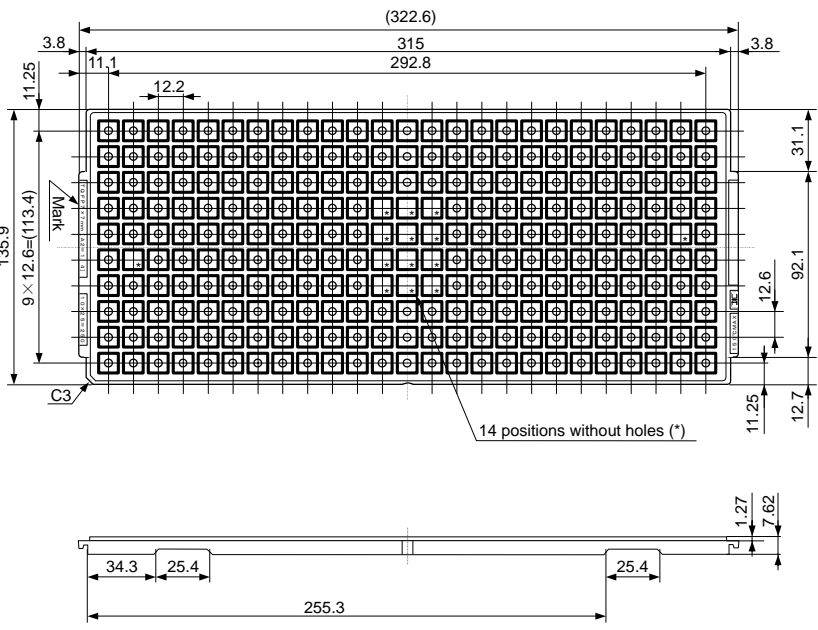
<p>1.Outer and inner packing</p>	 <p>Outer box (cardboard box)</p> <p>Inner</p>
<p>2.Tray</p>	<p>Tray Specifications Orientation of IC</p>  <p>Enlargement</p> <p>Tray Index</p> <p>IC Index</p> <p>Tray dimension</p>  <p>Unit: mm</p> <p>(1) Material of tray is PPE containing carbon and static proof. (2) Packing quantity is max 250 IC/Tray. (3) Maximum heat resistant temperature is 150°C.</p>

ECN3294TF

12. Inspection

Hundred percent inspections shall be conducted on electric characteristics.

13. Important Notice

13.1 Hitachi warrants performance of its power semiconductor products (hereinafter called “products”) to the specifications applicable at the time of sale in accordance with the Product Specification. Testing and other quality control techniques are utilized to the extent Hitachi needs to meet specifications described in the Product Specification. Specific testing of all parameters of each device is not necessarily performed, except those mandated by related laws and/or regulations.

13.2 Should any claim be made within one month of product delivery about products’ failure to meet performance described in the Product Specification, all the products in relevant lot(s) shall be re-tested and re-delivered. Products delivered more than one month before of such claim shall not be counted for such response.

13.3 Hitachi assumes no obligation or any way of compensation should any fault about customer’s goods using products be found in marketplace. Only in such a case fault of Hitachi is evident and products concerned do not meet the Product Specification, compensation shall be conducted if claimed within one year of product delivery up to in the way of product replacement or payment of equivalent amount.

13.4 Hitachi reserves the right to make changes in the Product Specification and to discontinue mass production of the relevant products without notice. Customers are advised before purchasing to confirm specification of the product of inquiry is the latest version and that the relevant product is on mass production status in such a case purchasing is suspended for one year or more.

13.5 In no event shall Hitachi be liable for any damage that may result from an accident or any other cause during operation of the user’s units according to this Product Specification. Hitachi assumes no responsibility for any intellectual property claims or any other problems that may result from applications of information, products or circuits described in this Product Specification.

13.6 No license is granted by this Product Specification under any patents or other rights of any third party or Hitachi, Ltd.

13.7 This Product Specification may not be reproduced or duplicated, in any form, in whole or in part, without the expressed written permission of Hitachi, Ltd.

13.8 The products (technologies) described in this Product Specification are not to be provided to any party whose purpose in their application will hinder maintenance of international peace and safety nor are they to be applied to that purpose by their direct purchasers or any third party. When exporting these products (technologies), the necessary procedures are to be taken in accordance with related laws and regulations.

ECN3294TF

14. Cautions

- 14.1 Customers are advised to follow the below cautions to protect semiconductor from electrical static discharge (ESD).
- a) IC needs to be dealt with caution to protect from damage by ESD. Material of container or any device to carry semiconductor devices should be free from ESD which may be caused by vibration while transportation. To use electric-conductive container or aluminum sheet is recommended as an effective countermeasure.
 - b) Those what touch semiconductor devices such as work platform, machine and measuring and test equipment should be grounded.
 - c) Workers should be grounded connecting with high impedance around 100k to 1M while dealing with semiconductor to avoid damaging IC by electric static discharge.
 - d) Friction with other materials such as a high polymer should not be caused.
 - e) Attention is needed so that electric potential will be kept on the same level by short circuit terminals when PC board with mounted IC is carried and that vibration or friction might not occur.
 - f) Air conditioning is needed so that humidity should not drop.
- 14.2 Refer to "Precautions for Use of High-Voltage Monolithic Ics" for the other precautions and instructions on how to deal with products.
- 14.3 Regardless of changes in external conditions during use, "absolute maximum ratings" should never be exceeded in designing electronic circuits that employ products. In a case absolute maximum ratings are exceeded, products may be damaged or destroyed. In no event shall Hitachi be liable for any failure in products or any secondary damage resulting from use at a value exceeding the absolute maximum ratings.
- 14.4 Products may experience failures due to accident or unexpected surge voltages. Accordingly, adopt safe design features, such as redundancy or prevention of erroneous action, to avoid extensive damage in the event of a failure.
- 14.5 Products are not designed, manufactured, or warranted to be suitable for use where extremely high reliability is required (such as use in nuclear power control, aerospace and aviation, traffic equipment, life-support-related medical equipment, fuel control equipment and various kinds of safety equipment).
- Inclusion of products in such application shall be fully at the risk of customers. Hitachi, Ltd. assumes no liability for applications assistance, customer product design, or performance. In such cases it is advised customers ensure circuit and/or product safety by using semiconductor devices that assures high reliability or by means of user's fail-safe precautions or other arrangement.
- (If a semiconductor device fails, there may be cases in which the semiconductor device, wiring or wiring pattern will emit smoke or cause a fire or in which the semiconductor device will burst.)
- 14.6 Lead-free solder is used for coating pins and the tab of this IC. Refer to "Precautions for Use of High-Voltage Monolithic Ics" for soldering conditions.

Precautions for Safe Use and Notices

If semiconductor devices are handled in inappropriate manner, failures may result. For this reason, be sure to read "Precaution for Use" before use.



This mark indicates an item about which caution is required.



CAUTION

This mark indicates a potentially hazardous situation which, if not avoided, may result in minor or moderate injury and damage to property.



CAUTION

- (1) Regardless of changes in external conditions during use "absolute maximum ratings" should never be exceeded in designing electronic circuits that employ semiconductors. In the case of pulse use, furthermore, "safe operating area (SOA)" precautions should be observed.
- (2) Semiconductor devices may experience failures due to accident or unexpected surge voltages. Accordingly, adopt safe design features, such as redundancy or prevention of erroneous action, to avoid extensive damage in the event of a failure.
- (3) In cases where extremely high reliability is required (such as use in nuclear power control, aerospace and aviation, traffic equipment, life-support-related medical equipment, fuel control equipment and various kinds of safety equipment), safety should be ensured by using semiconductor devices that feature assured safety or by means of user's fail-safe precautions or other arrangement. Or consult Hitachi's sales department staff.

(If a semiconductor device fails, there may be cases in which the semiconductor device, wiring or wiring pattern will emit smoke or cause a fire or in which the semiconductor device will burst)

NOTICES

1. This Data Sheet contains the specifications, characteristics (in figures and tables), dimensions and handling notes concerning power semiconductor products (hereinafter called "products") to aid in the selection of suitable products.
2. The specifications and dimensions, etc. stated in this Data Sheet are subject to change without prior notice to improve products characteristics. Before ordering, purchasers are advised to contact Hitachi's sales department for the latest version of this Data Sheet and specifications.
3. In no event shall Hitachi be liable for any damage that may result from an accident or any other cause during operation of the user's units according to this Data Sheet. Hitachi assumes no responsibility for any intellectual property claims or any other problems that may result from applications of information, products or circuits described in this Data Sheet.
4. In no event shall Hitachi be liable for any failure in a semiconductor device or any secondary damage resulting from use at a value exceeding the absolute maximum rating.
5. No license is granted by this Data Sheet under any patents or other rights of any third party or Hitachi, Ltd.
6. This Data Sheet may not be reproduced or duplicated, in any form, in whole or in part, without the expressed written permission of Hitachi, Ltd.
7. The products (technologies) described in this Data Sheet are not to be provided to any party whose purpose in their application will hinder maintenance of international peace and safety nor are they to be applied to that purpose by their direct purchasers or any third party. When exporting these products (technologies), the necessary procedures are to be taken in accordance with related laws and regulations.