

ECN3067

ECN3067 is monolithic IC integrating 6 IGBTs.

It can be applied to DC brushless motors and Induction motors.

Functions

- Free Wheeling Diodes are integrated
- Overcurrent Protection Circuit is integrated
- Undervoltage Detection Circuit is integrated

Features

- PWM control of upper and bottom arm IGBTs are possible with an outer Microprocessor.
- 6 Logic inputs are compatible with 5V CMOS or LSTTL outputs.
- Upper and Bottom arm IGBTs can operate in 20kHz chopping frequency.
- For converted AC200 to 230 V power supplies PWM control of top and bottom arm IGBTs are possible.

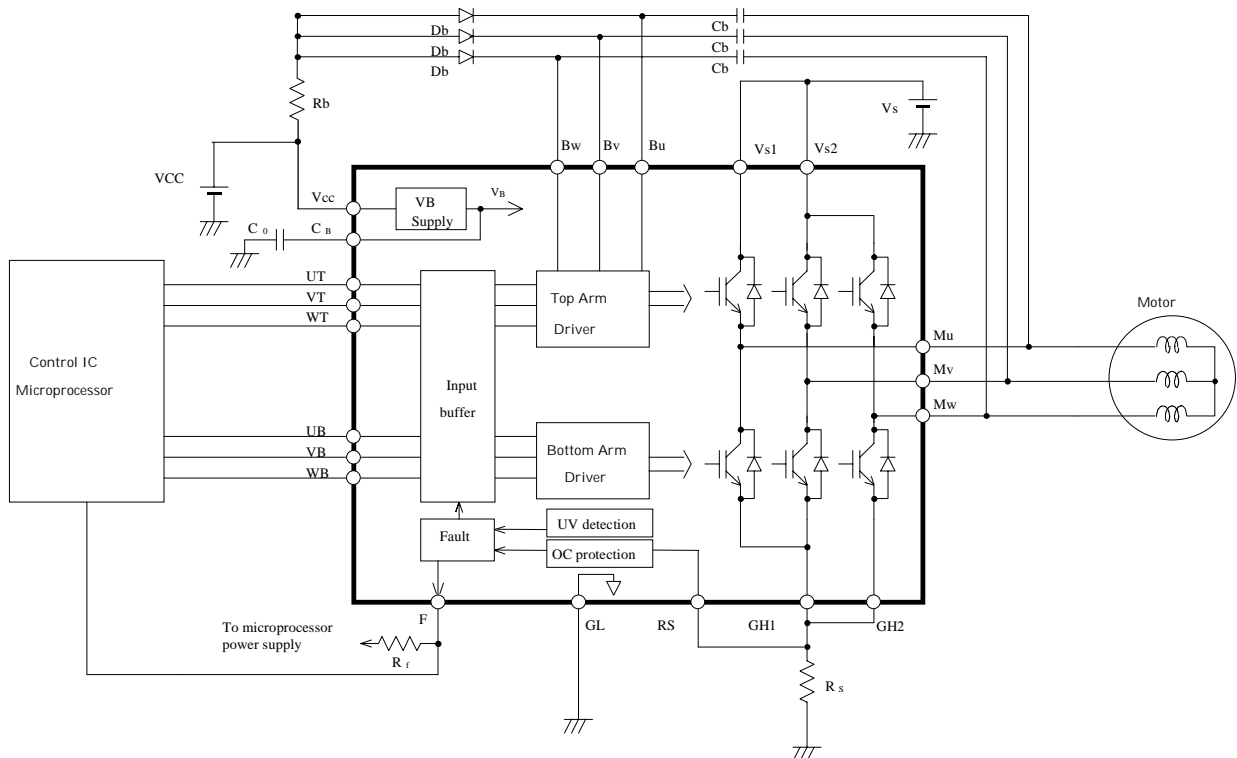

Fig.1 Block Diagram(example for boot strap)

ECN3067

1. General

- (1) Type : ECN3067SLV, ECN3067SLR
 (2) Application : 3-Phase DC Brushless Motors and Induction Motors
 (3) Structure : Monolithic IC
 (4) Package : SP-23TE, SP-23TFA

2. Absolute Maximum Allowable Ratings (Ta=25°C)

No.	Items	Symbols	Terminal	Ratings	Unit	Condition
1	Output Device Breakdown Voltage	VSM	VS1,VS2 MU,MV,MW	500	V	
2	Supply Voltage	VCC	VCC	18	V	
3	Input Voltage	VIN	UT,VT,WT, UB,VB,WB	-0.5~VB+0.5	V	
4	Output Current	IOM	MU,MV,MW	5.0	A	Note 1
5	Operating Junction Temperature	Tjop		-20~+135	°C	Note 2
6	Storage Temperature	Tstg		-40~+150	°C	

Note 1. Recommended Safety Operation Area

It is recommended that this IC is used within the SOA as shown below where IM and VM are the current and the voltage at the terminal of motor wiring at the change of phase (turn on and turn off).

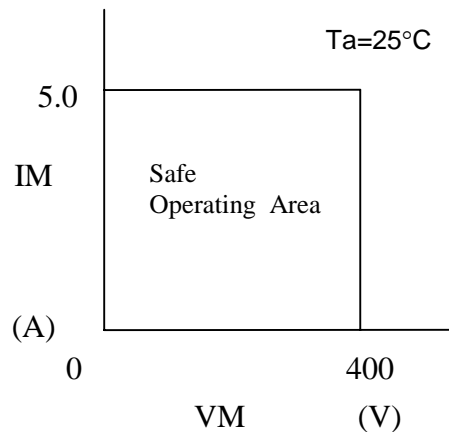

Note 2. Thermal Resistance

$$R_{jc} = 1.5^{\circ}\text{C/W}$$

3. Recommended Operating Conditions

No.	Items	Symbols	Terminal	MIN.	TYP.	MAX.	Unit	Condition
1	Supply Voltage	VS	VS1,VS2	50	–	400	V	
2		VCC	VCC	13.5	15	16.5	V	
3	Supply Current	IS	VS1,VS2	–	–	2.5	A	

ECN3067

4. Electrical Characteristics

Unless otherwise specified, $V_{CC}=15V, V_S=325V$

Suffix T: Top arm B: Bottom Arm

$T_a = 25^\circ C$

No.	Items	Symbols	Terminal	MIN.	TYP.	MAX.	Unit	Condition	
1	Standby Current	IS	VS1,VS2	–	–	0.25	mA	Input="H"	
2		ISB	BU-MU,BV-MV,BW-MW	–	15	30	μA	BU-MU,BV-MV, BW-MW=15V	
3		ICC	VCC	–	10	20	mA		
4	Output device FVD	VFT	MU,MV,MW	–	2.5	3.5	V	I=1.5A PW<5ms	
5		VFB	MU,MV,MW	–	2.5	3.5	V	I=1.5A PW<5ms	
6	Turn On Delay Time	TdONT	MU,MV,MW	–	1.0	2.0	μs	I=1.5A Resistive Load	
7		TdONB	MU,MV,MW	–	1.0	2.0	μs		
8	Turn Off Delay Time	TdOFFT	MU,MV,MW	–	1.0	2.0	μs		
9		TdOFFB	MU,MV,MW	–	1.0	2.0	μs		
10	Diode FVD	VFDT	MU,MV,MW	–	2.5	3.5	V	I=1.5A PW<5ms	
11		VFDB	MU,MV,MW	–	2.5	3.5	V		
12	Input Voltage	VIH	UT,VT,WT,	3.5	–	–	V		
13		VIL	UB,VB,WB	–	–	1.5	V		
14	Input Current	IIL	UT,VT,WT, UB,VB,WB	-100	–	–	μA	Input=0V Note 1	
15		IIH		-30	–	–	μA	Input=5V Note 1	
16	VB Output Voltage	VB	CB	6.8	7.5	8.2	V		
17	VB Output Current	IB	CB	50	–	–	mA	$\delta V_{LOAD}=0.2V$	
18	Over Current reference Voltage	Vref	RS	0.45	0.5	0.55	V		
19	Fault output on resistance	Ronf	F	–	300	400	Ω	Note 2	
20	Vcc Under Voltage	Negative Going	Vuvb	VCC	9.8	11.4	13.0	V	Note 3
21		Reset Hysterisis	Vrhb	VCC	0.1	0.4	0.9	V	
22	VBU,BV,BW Under Voltage	Negative Going	Vuvt	BU-MU,BV-	9.8	11.4	13.0	V	Note 4
23		Reset Hysterisis	Vrht	MV,BW-MW	0.1	0.4	0.9	V	
24	Fault reset delay time	tflrs	F	6.5	10	20	μs		
25	OC shutdown delay	toc	RS	–	2.0	3.0	μs		

Note 1. Pull Up Resistance are typically 200k Ω

Note 2. The equivalent circuit around F terminal is shown below.

Note 3. Please see item 5.4.

Note 4. Please see item 5.4.

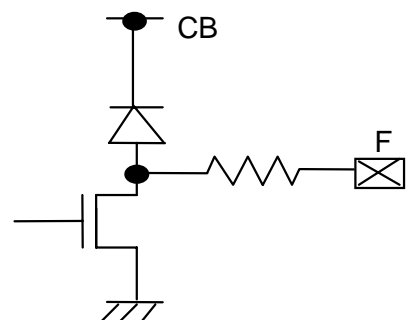

ECN3067

5. Function

5.1. Truth Table

Terminal	Input	Output
UT,VT,WT, UB,VB,WB	L	ON
	H	OFF
UT,UB	UT&UB=L	OFF
VT,VB	VT&VB=L	OFF
WT,WB	WT&WB=L	OFF

5.2 Timing Chart(Example of Brushless Motor drive)

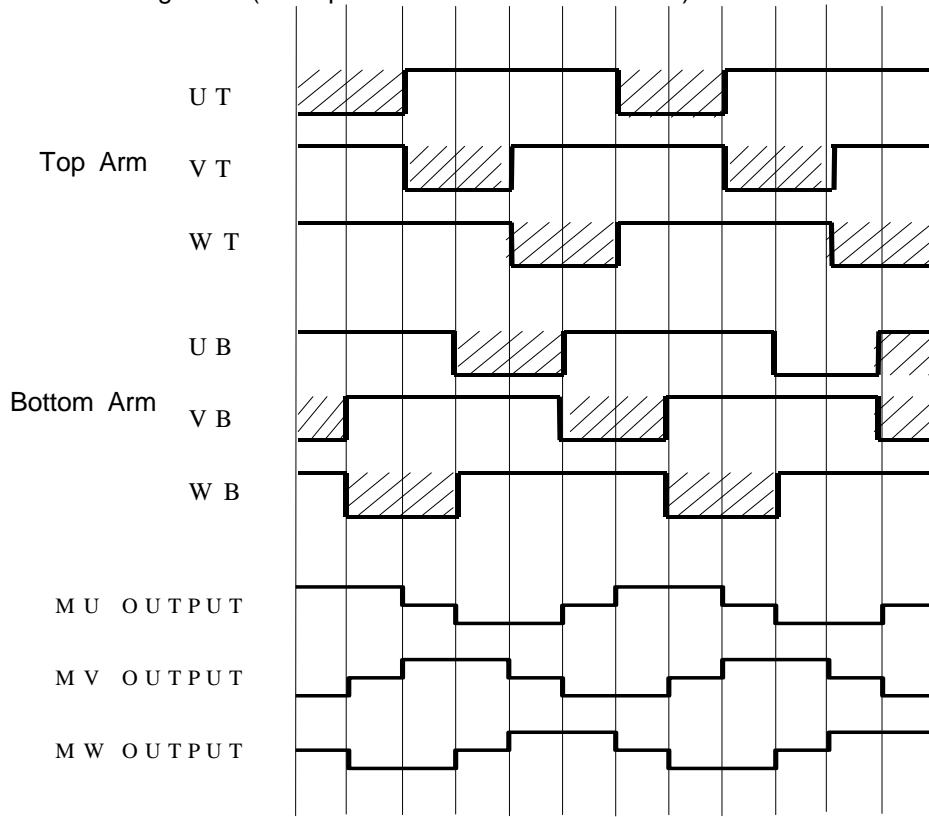

5.3 Over Current Operation

This IC detects over current by checking the Voltage drop at the external resistance RS. When the input voltage at RS terminal exceeds the internal reference voltage (Vref), this IC turns off the output of all arms circuit and F terminal output becomes “L”. After over current detection, reset is done when all six inputs are referenced to high level.

In case of not using this function, please connect this terminal to GL terminal (within 100 Ω).

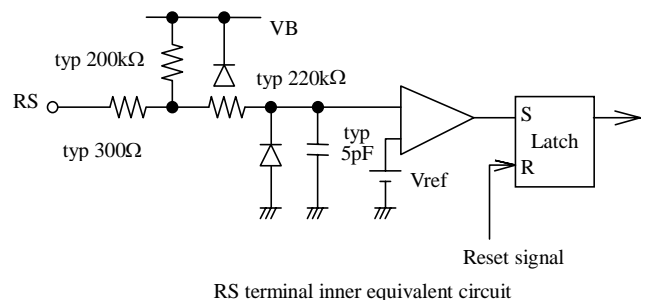

ECN3067

5.4 Undervoltage Detection

- 1) When V_{cc} supply voltage becomes below $V_{uvb}(11.4V \text{ typ.})$, all of the IGBTs shut off and F terminal output becomes "L".
 - 2) When between BU-MU, BV-MV or BW-MW voltage become below $V_{uvt}(11.4V \text{ typ.})$, top arm IGBT of under voltage detected phase shuts off. In this time, F terminal output doesn't change.
- Note 1. When V_{CC} supply voltage becomes lower, driving capability of IGBT also becomes lower. Accordingly, power dissipation becomes higher and this causes temperature raise of IC. In case of junction temperature exceeds $135^{\circ}C$, IC may deteriorate or breakdown.

5.5 Definition of switching delay

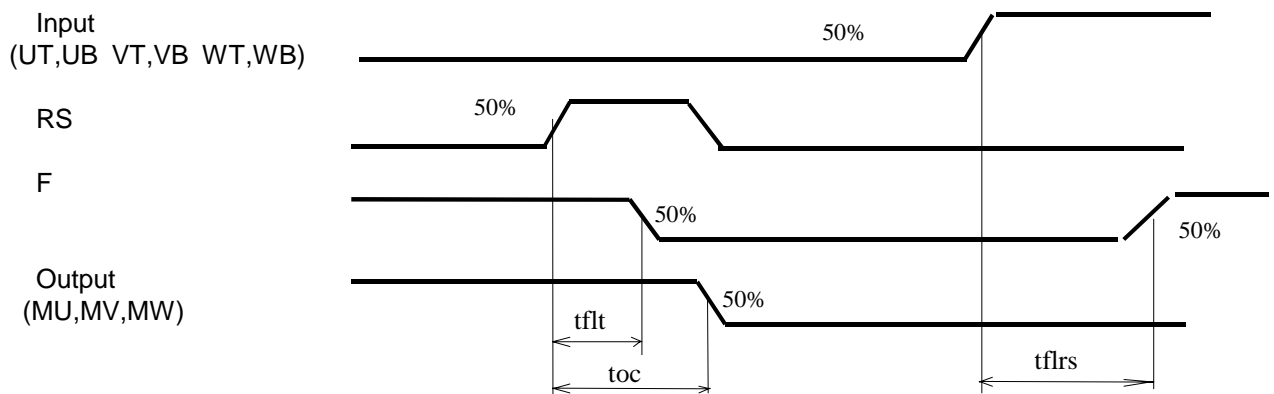
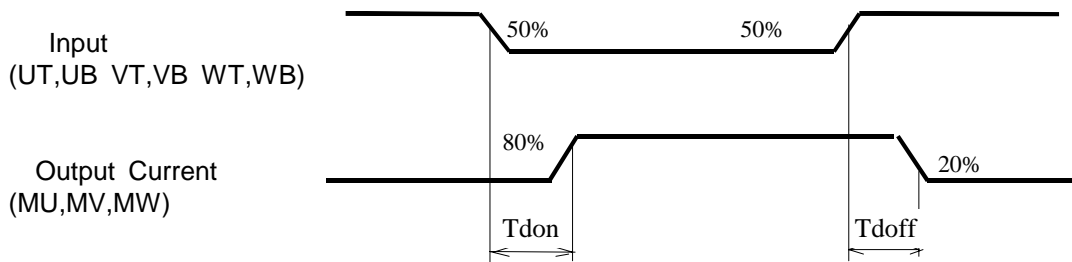

ECN3067

6. Standard Application

No	ITEMS	SYMBOLS	UNIT	VALUESTOL.	REMARK
1	VB Smoothing Capacitor	Co	μF	≥ 0.22	Stress Voltage 8V
2	Boot Strap Capacitor	Cb	μF	≥ 3.3	Stress Voltage Vcc
3	Boot Strap Diode	Db	-	Hitachi DFG1C6, DFM1F6 or equivalent	Breakdown Voltage : ≥ 600V, Current : ≥1.0A Trr : ≤ 200ns
4	Sensing Resistor	Rs	Ω	Note1	
5	Load resistor for F terminal	Rf	kΩ	≥ 5.6	
6	Resistor of boot strap	Rb	Ω	Note2	

Note1. Over-current detection level is determined by the following equation.

$$I_o = V_{ref} / R_s \quad (A)$$

Note2. Current limiting resistance Rb is prevention over current protection from operation at initial charge. Rb is about determined by the following equation.

$$I_{bpeak} = V_{ref} / R_s = V_{CC} / R_b$$

$$R_b > (V_{CC} * R_s) / V_{ref} * 2$$

(* 2 shows the margin. Top arms are off state. I_{bpeak} is one phase only.)

I_{bpeak} : Peak current of the initial charge for C_b

V_{ref} ; Over Current reference Voltage

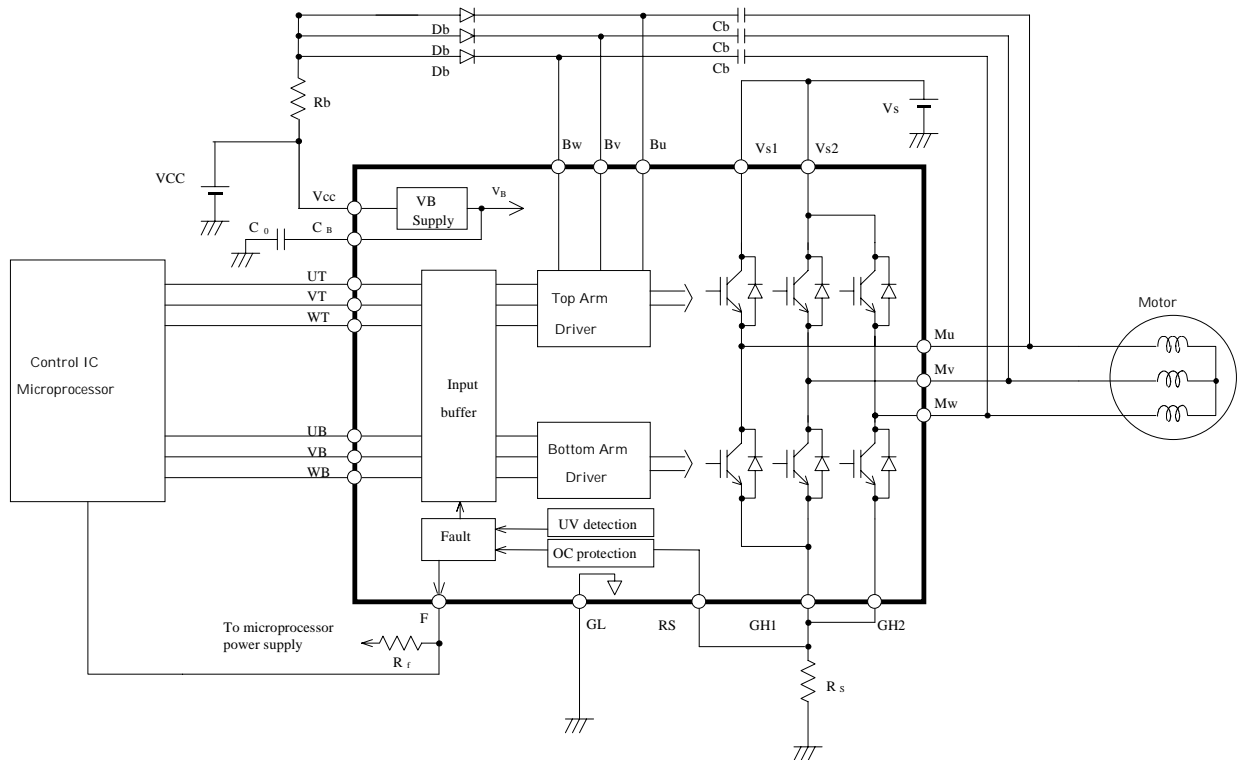

Block Diagram(example for boot strap)

ECN3067

7. Pin Assignment

Pin No.	Terminal Name	Pin No.	Terminal Name
1	MV	13	VB
2	VS2	14	UB
3	MW	15	WT
4	GH2	16	VT
5	BW	17	UT
6	BV	18	BU
7	VCC	19	VS1
8	CB	20	Non Connection
9	GL	21	Non Connection
10	F	22	MU
11	RS	23	GH1
12	WB		

8. Package Outline

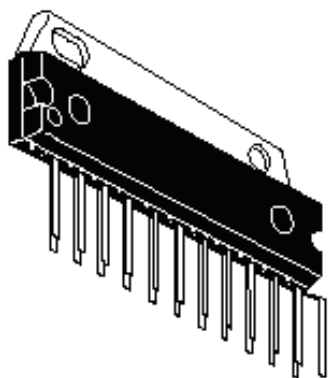

ECN3067SLV
(SP-23TE)

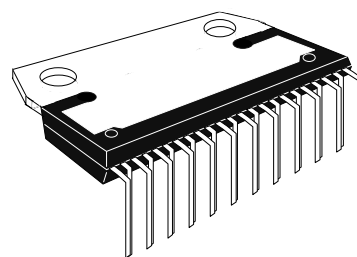

ECN3067SLR
(SP-23TFA)

ECN3067

9.Package Dimension (unit: mm)

(1) ECN3067SLV

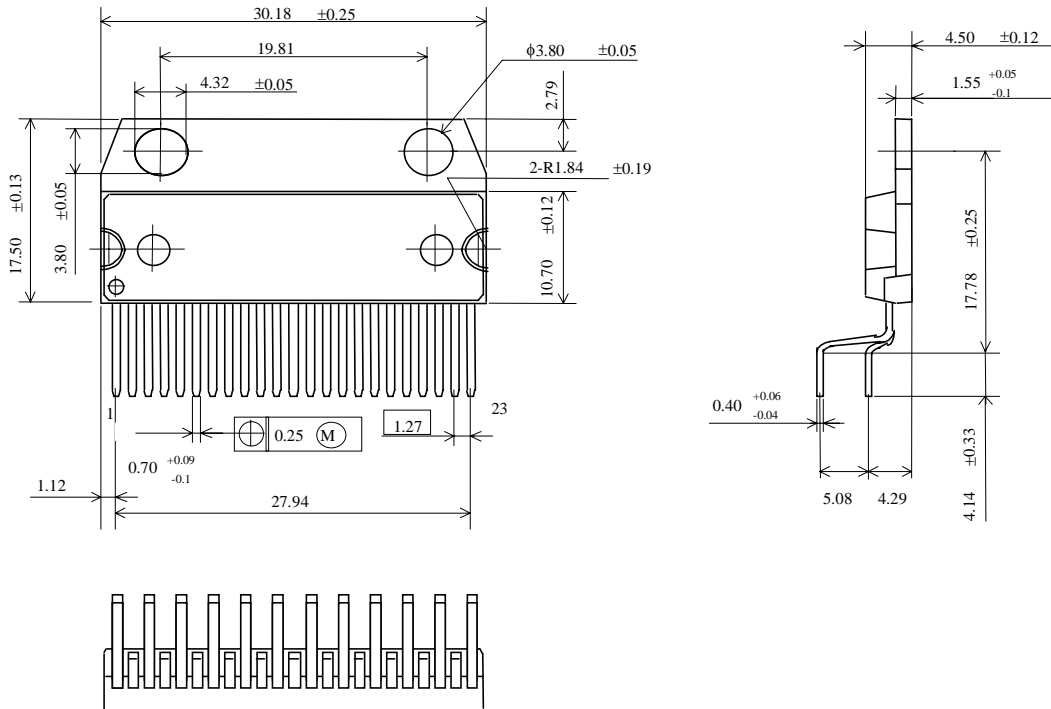

(2) ECN3067SLR

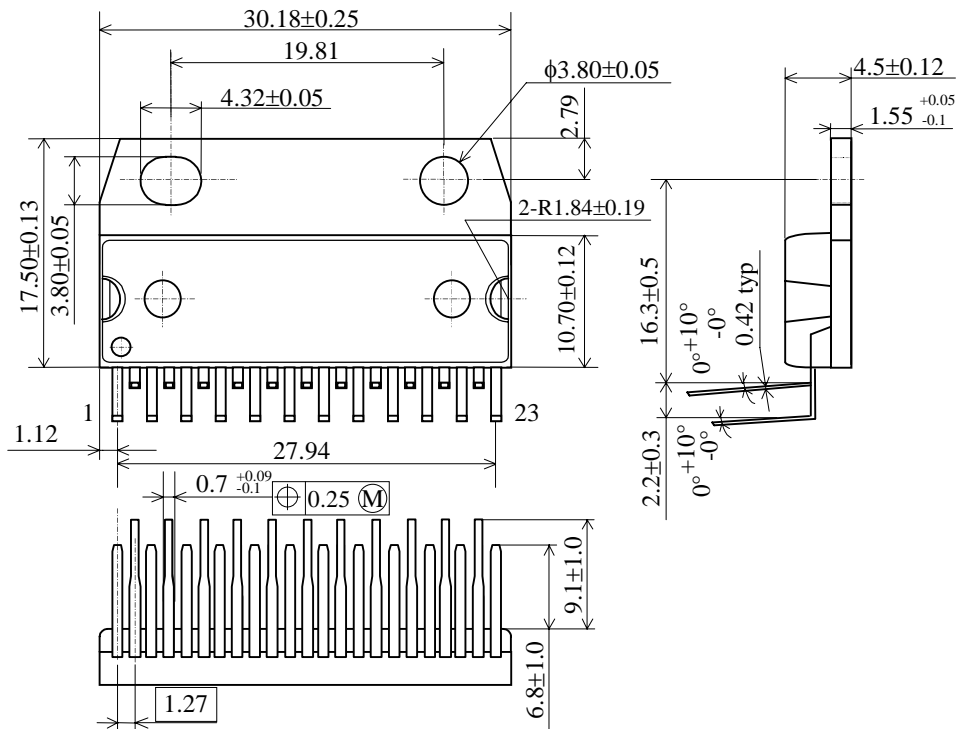

ECN3067

10. Note of the design margin under the SOA

Following figure indicates the evaluation as the reference of the SOA (safety operation area) under the $T_j=135^\circ\text{C}$ (the junction temperature is equal to 135°C). Dot mark (•) shows the points of the IC destruction. The plural points under the same voltage indicate the dispersion of the sample.

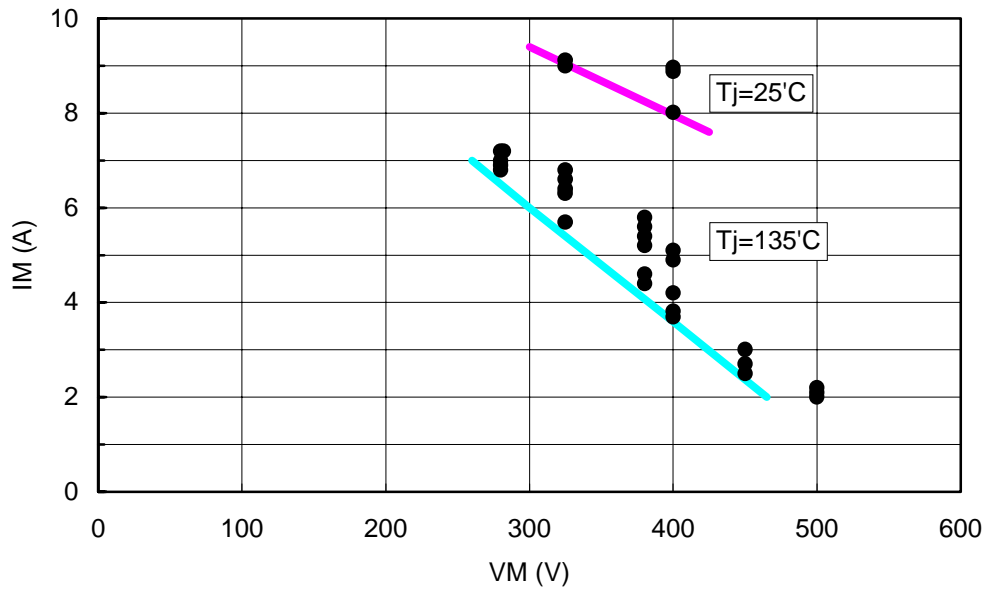

Fig. The Safety Operation Area in ECN3067 (reference)

In this figure, IM and VM are the current and the voltage at the terminal of motorwiring at the change of phase (turn on and turn off).

HITACHI POWER SEMICONDUCTORS

Notices

1. The information given herein, including the specifications and dimensions, is subject to change without prior notice to improve product characteristics. Before ordering, purchasers are advised to contact Hitachi sales department for the latest version of this data sheets.
2. Please be sure to read "Precautions for Safe Use and Notices" in the individual brochure before use.
3. In cases where extremely high reliability is required (such as use in nuclear power control, aerospace and aviation, traffic equipment, life-support-related medical equipment, fuel control equipment and various kinds of safety equipment), safety should be ensured by using semiconductor devices that feature assured safety or by means of users' fail-safe precautions or other arrangement. Or consult Hitachi's sales department staff.
4. In no event shall Hitachi be liable for any damages that may result from an accident or any other cause during operation of the user's units according to this data sheets. Hitachi assumes no responsibility for any intellectual property claims or any other problems that may result from applications of information, products or circuits described in this data sheets.
5. In no event shall Hitachi be liable for any failure in a semiconductor device or any secondary damage resulting from use at a value exceeding the absolute maximum rating.
6. No license is granted by this data sheets under any patents or other rights of any third party or Hitachi, Ltd.
7. This data sheets may not be reproduced or duplicated, in any form, in whole or in part , without the expressed written permission of Hitachi, Ltd.
8. The products (technologies) described in this data sheets are not to be provided to any party whose purpose in their application will hinder maintenance of international peace and safety not are they to be applied to that purpose by their direct purchasers or any third party. When exporting these products (technologies), the necessary procedures are to be taken in accordance with related laws and regulations.

- For inquiries relating to the products, please contact nearest overseas representatives which is located "Inquiry" portion on the top page of a home page.

Hitachi power semiconductor home page address <http://www.pi.hitachi.co.jp/pse>

HITACHI