

HIGH-VOLTAGE MONOLITHIC IC

ECN3054

ECN3054 is a single chip driver IC which has 6 MOS-Gated devices for its output. It is suitable for controlling 3-phase brushless DC motors and 3-phase induction motors.

Functions

- Lower arm Over current (OC) Protection
- Under voltage Protection
- Fault Output function

Package

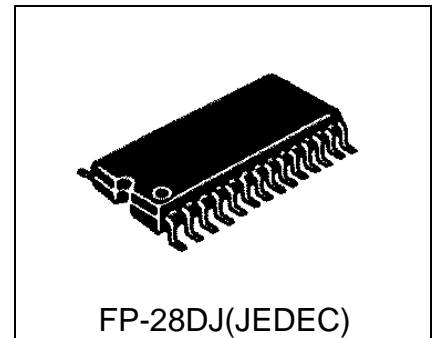

Features

- It can be controlled by PWM with 6 inputs from an external microprocessor.
- 6 logic inputs are compatible with 5V CMOS.

Block Diagram

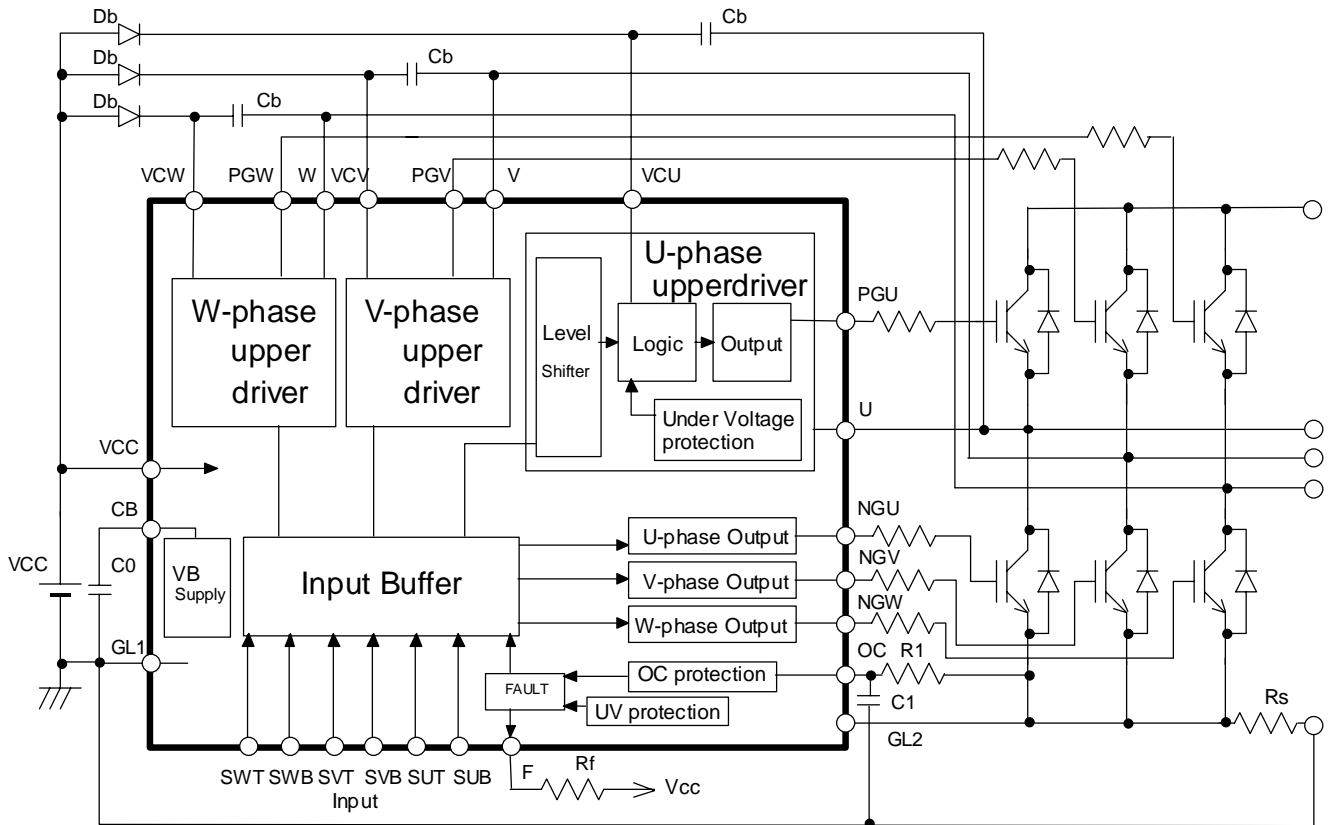

Block diagram

ECN3054

1. General

This specification shall be applied to the following semiconductor integrated circuits.

- 1) Type : ECN3054F
- 2) Application : 3-phase Brushless DC Motor, 3-phase Induction Motor
- 3) Structure: Monolithic IC
- 4) Package : FP-28DJ (JEDEC)

2. Maximum Allowable Ratings (Ta=25 °C)

| No. | ITEMS | SYMBOLS | VALUES | UNIT | CONDITIONS |
|-----|---------------------------------|---------|--------------|------|-----------------------|
| 1 | Output Device Breakdown Voltage | Vbv | 620 | V | Between VCU,V,W & GL1 |
| 2 | GL2 terminal voltage | Vgl2 | -5~Vcc | V | Vcc=18Vmax at GL2=-5V |
| 3 | U,V,W terminal Voltage | Vu,v,w | -5~600 | V | |
| 4 | Supply voltage | Vcc | 20 | V | |
| 5 | Input voltage | Vin | -0.5~Vcc+0.5 | V | |
| 6 | Operating Junction Temperature | Tjop | -20~125 | °C | |
| 7 | Storage Temperature | Tstg | -40~150 | °C | |

Note 1 : Thermal resistance Rja

| PACKAGE | FP-28DJ | UNIT |
|------------|------------------|------|
| Single | 121 | °C/W |
| Mounted | 84 | °C/W |
| PCB size * | 120x21x1.6 (30%) | (mm) |

* This figure varies depending on the mounting condition.

3. Recommended Operating Conditions

| No. | ITEMS | SYMBOLS | VALUES TOL. | UNIT | CONDITIONS |
|-----|------------------------|---------|-------------|------|------------|
| 1 | U,V,W terminal Voltage | Vu,v,w | -3 ~ 400 | V | |
| 2 | Supply Voltage | Vcc | 13.5 ~ 16.5 | V | |

ECN3054

4. Electrical Characteristics

Unless otherwise noted, Ta=25°C, Vu,v,w to GL1=374V, Vcc=15V. (suffix T=top, B=bottom arm)

| No | ITEMS | SYMBOLS | MIN | TYP | MAX | UNIT | CONDITIONS |
|----|-----------------------------------|------------------|------|------|---------|------|---|
| 1 | Stand-by current | Is1 | - | 6.5 | 10 | mA | Vin=H or L , Between Vcc-GL1 |
| | | Is2 | - | 15 | 30 | μA | Between VCU-U,VCV-V,VCW-W 15V, Vin=H or L |
| 2 | Input Voltage (Output is L) | VIH | 3.5 | - | - | V | Input=H or L |
| | Input Voltage (Output is H) | VIL | - | - | 1.5 | V | |
| 3 | Output Source Current | Io+ | 0.2 | 0.25 | - | A | VCU-PGU,VCV-PGV,VCW-PGW=15V, Vcc-NGU,V,W =15V PW<10μs |
| 4 | Output Sink Current | Io- | 0.4 | 0.5 | - | A | PGU-U,PGV-V, PGW-W =15V, NGU,V,W -GL2=15V PW<10μs |
| 5 | High level Output Voltage | VOH | - | - | 100 | mV | VCU,V,W-PGU,V,W & Vcc-NGU,V,W Vin=0V, Io=0A |
| 6 | Low level Output Voltage | VOL | - | - | 100 | mV | PGU,V,W-U,V,W & NGU,V,W-GL2 Vin=5V,Io=0A |
| 7 | Leakage Current at HV terminal | IL | - | - | 50 | μA | VCU,V,W=U,V,W=600V |
| 8 | Input Current | IIL | -200 | - | - | μA | Vin=0V Internal Pull up R=200kΩ |
| 9 | Input Current | IIH | -120 | - | - | μA | Vin=5V Internal Pull up R=200kΩ |
| 10 | Vcc Under Voltage | Negative Going | Vuvb | 9.5 | 10.5 | 11.6 | V |
| | | Reset Hysterisis | Vrhb | 0.1 | 0.4 | 0.9 | V |
| 11 | Vcu,v,w Under Voltage | Negative Going | Vuvt | 8.9 | 10.5 | 12.1 | V |
| | | Reset Hysterisis | Vrht | 0.1 | 0.4 | 0.9 | V |
| 12 | OC Input Positive Going threshold | Voc | 0.44 | 0.49 | 0.54 | V | |
| 13 | Fault Output On Resistance | Ronf | - | 300 | 400 | Ω | F-GL1=0.5V |
| 14 | Turn On Delay Time | ton | - | 0.8 | 1.5 | μs | CL=1000pF RL=0Ω |
| 15 | Turn Off Delay Time | toff | - | 0.5 | 1.2 | μs | CL=1000pF RL=0Ω |
| 16 | OC Output Shutdown Delay | toc | - | 0.7 | 1.7 | μs | CL=1000pF RL=0Ω |
| 17 | Fault Output Delay | tflt | - | 0.6 | 1.6 | μs | CL=1000pF RL=0Ω |
| 18 | Fault Reset Delay Time | tflrs | 6.5 | 10 | 20 | μs | CL=1000pF RL=0Ω |
| 19 | Fault output terminal voltage | Vflt | -0.5 | - | Vcc+0.5 | V | |
| 20 | Fault output sink current | Iflt | 4 | - | - | mA | Vcc=15V,F-GL=2V |
| 21 | VB output Voltage | VB | 6.8 | 7.5 | 8.2 | V | Output current=0mA |
| 22 | VB output current | IB | 15 | 20 | - | mA | DeltaVload=0.2V |

Note 1: Vuvb, Vrhb, Vuvt and Vrht are defined and shown in Fig. 1

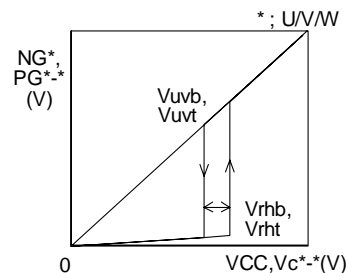

Fig 1. Negative going and reset voltage and hysteresis for the top and bottom arm under voltage circuit

ECN3054

5. Truth Table

| INPUT | | OC Input | U phase | | V phase | | W phase | | |
|---------|---|----------|---------|---------|---------|---------|---------|---------|-----|
| | | | Top arm | Bot.arm | Top arm | Bot.arm | Top arm | Bot.arm | |
| SUT | L | L | ON | - | - | - | - | - | |
| | H | | OFF | - | - | - | - | - | |
| SUB | L | | - | ON | - | - | - | - | |
| | H | | - | OFF | | | | - | |
| SVT | L | | - | - | ON | | | - | |
| | H | | - | - | OFF | | | - | |
| SVB | L | | - | - | - | ON | | - | |
| | H | | - | - | - | OFF | | - | |
| SWT | L | | - | - | - | - | ON | - | |
| | H | | - | - | - | - | OFF | - | |
| SWB | L | | - | - | - | - | - | ON | |
| | H | | - | - | - | - | - | OFF | |
| - | - | | H | OFF | OFF | OFF | OFF | OFF | OFF |
| SUT,SUB | L | | L | OFF | OFF | - | - | - | - |
| SVT,SVB | L | | L | - | - | OFF | OFF | - | - |
| SWT,SWB | L | | L | - | - | - | - | OFF | OFF |

Note 1: Fault output level is referenced Low when over current or under voltage for Vcc is detected.

Note 2: Over current protection works when the voltage drop of the external sensing resistor exceeds the threshold voltage Voc. In this case all six outputs are turned off and Fault output level becomes low.

Reset after detection is done by feeding high signal to all six inputs or re-supplying Vcc voltage.

Note 3: The output signal for Fault is reset by feeding high signal to all six inputs.

ECN3054

6. Definition of switching delay

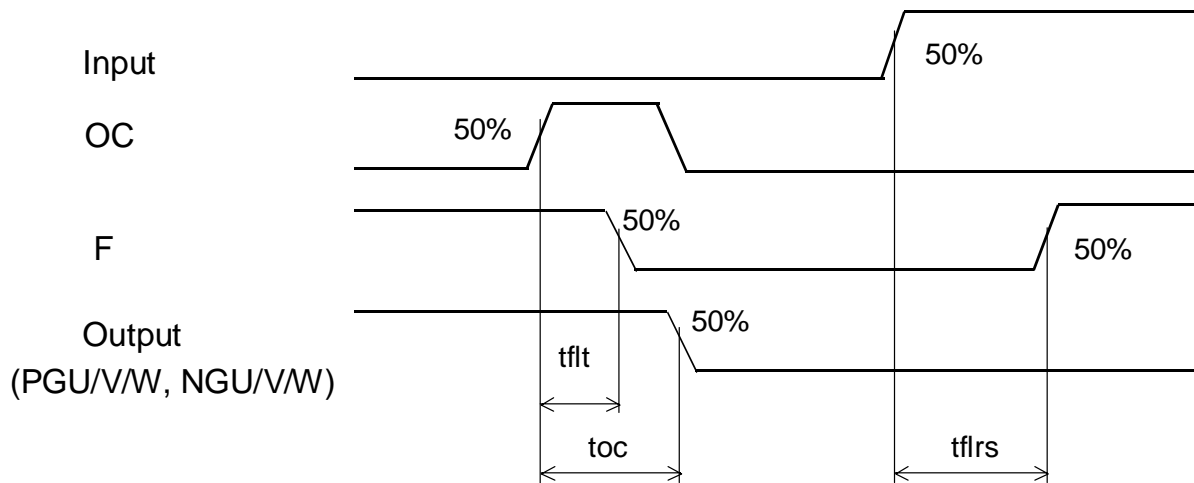
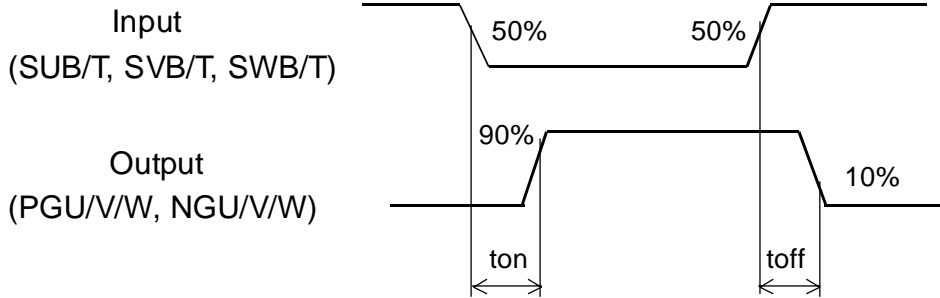

ECN3054

7. Standard Application

| No. | ITEMS | SYMBOLS | VALUES TOL. | UNIT | CONDITIONS |
|-----|------------------------------|---------|--|------|--------------------------|
| 1 | PWM Frequency | fpwm | 1 ~ 20 | kHz | |
| 2 | VB Smoothing Capacitor | Co | 0.22 ± 20% | μF | Stress voltage:VB |
| 3 | Boot Strap Capacitor | Cb | 3.3 ± 20% | μF | Stress voltage:Vcc |
| 4 | Boot Strap Diodes | Db | Hitachi DFG1C6 DFM1F6 or equivalent | - | 600V/1.0A trr ≤ 0.1μs |
| 5 | Sensing Resistor | Rs | Note 1 | Ω | |
| 6 | OC Filtering Resistor | R1 | Note 2 | Ω | |
| 7 | OC Filtering Capacitor | C1 | Note 2 | μF | |
| 8 | Load resistor for F terminal | Rf | 5.6 ± 20% | kΩ | |

Note 1. Over-current detection level is determined by the following equation

$$I_{oc} = V_{oc} / R_s \text{ (A)}$$

Note.2 This IC has filters of 0.4us for noise reduction.

But appropriate R1, C1 should be added when noise can not be removed.

8. Pin Assignment

| | | | |
|----|-----|-----|----|
| 1 | VCC | VCU | 28 |
| 2 | SUT | PGU | 27 |
| 3 | SVT | U | 26 |
| 4 | SWT | N.C | 25 |
| 5 | SUB | VCV | 24 |
| 6 | SVB | PGV | 23 |
| 7 | SWB | V | 22 |
| 8 | F | N.C | 21 |
| 9 | OC | VCW | 20 |
| 10 | CB | PGW | 19 |
| 11 | N.C | W | 18 |
| 12 | GL1 | N.C | 17 |
| 13 | GL2 | NGU | 16 |
| 14 | NGW | NGV | 15 |

ECN3054

9. Outline Drawing

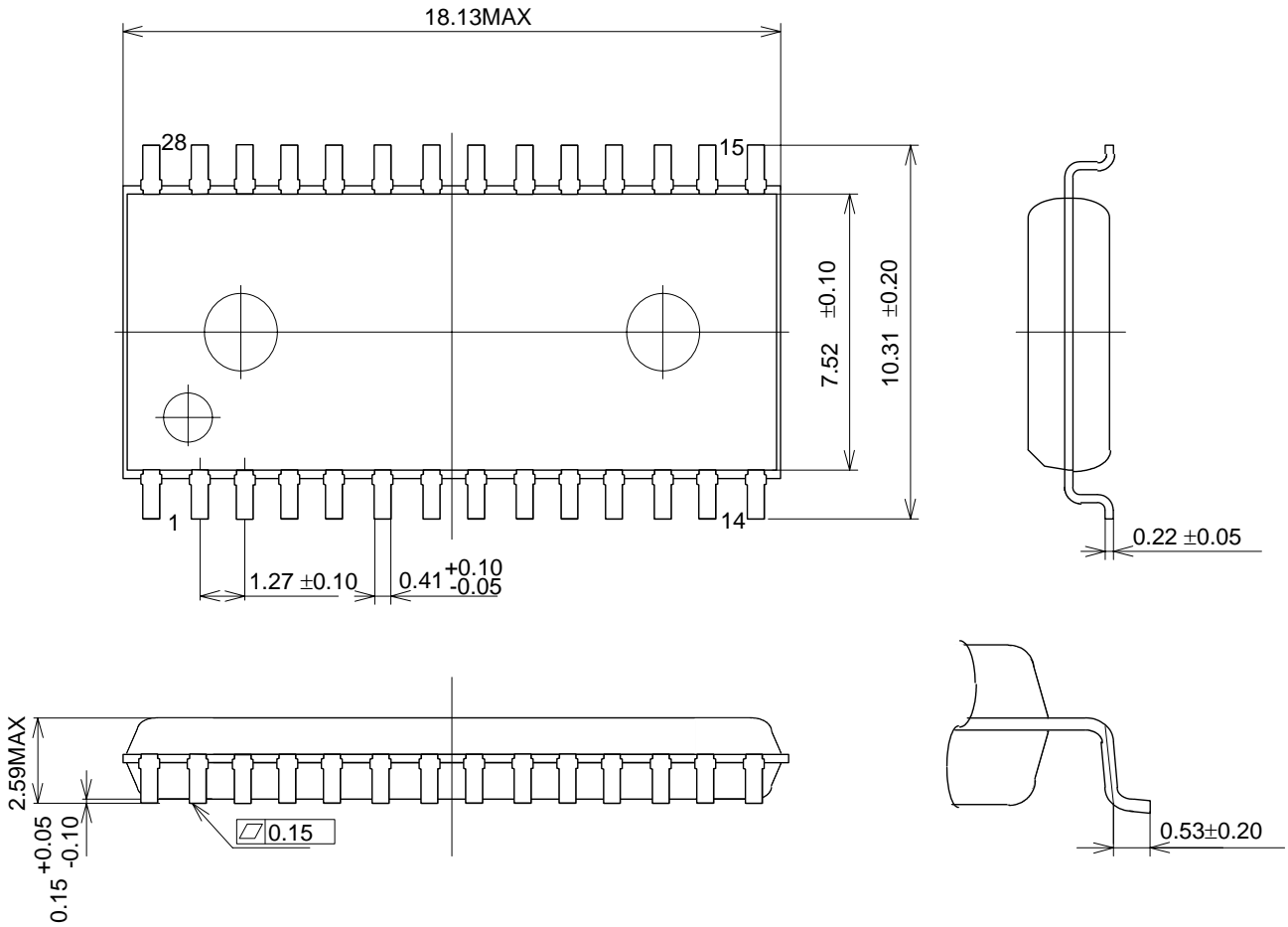

HITACHI POWER SEMICONDUCTORS

Notices

1. The information given herein, including the specifications and dimensions, is subject to change without prior notice to improve product characteristics. Before ordering, purchasers are advised to contact Hitachi sales department for the latest version of this data sheets.
2. Please be sure to read "Precautions for Safe Use and Notices" in the individual brochure before use.
3. In cases where extremely high reliability is required (such as use in nuclear power control, aerospace and aviation, traffic equipment, life-support-related medical equipment, fuel control equipment and various kinds of safety equipment), safety should be ensured by using semiconductor devices that feature assured safety or by means of users' fail-safe precautions or other arrangement. Or consult Hitachi's sales department staff.
4. In no event shall Hitachi be liable for any damages that may result from an accident or any other cause during operation of the user's units according to this data sheets. Hitachi assumes no responsibility for any intellectual property claims or any other problems that may result from applications of information, products or circuits described in this data sheets.
5. In no event shall Hitachi be liable for any failure in a semiconductor device or any secondary damage resulting from use at a value exceeding the absolute maximum rating.
6. No license is granted by this data sheets under any patents or other rights of any third party or Hitachi, Ltd.
7. This data sheets may not be reproduced or duplicated, in any form, in whole or in part , without the expressed written permission of Hitachi, Ltd.
8. The products (technologies) described in this data sheets are not to be provided to any party whose purpose in their application will hinder maintenance of international peace and safety not are they to be applied to that purpose by their direct purchasers or any third party. When exporting these products (technologies), the necessary procedures are to be taken in accordance with related laws and regulations.

■ For inquiries relating to the products, please contact nearest overseas representatives which is located "Inquiry" portion on the top page of a home page.

Hitachi power semiconductor home page address <http://www.hitachi.co.jp/pse>

HITACHI