

ECN30531F

1. General

This specification shall be applied to the following semiconductor integrated circuits.

- 1) Type : ECN30531F
- 2) Application : 3-phase Brushless DC Motor, 3-phase Induction Motor
- 3) Structure: Monolithic IC
- 4) Package : FP-28DJ (JEDEC) Lead(Pb)-free (SnBi type)

2. Maximum Allowable Ratings (Ta=25 °C)

No.	ITEMS	SYMBOLS	VALUES	UNIT	CONDITIONS
1	Output Device Breakdown Voltage	Vbv	620	V	Between VCU,V,W & GL1
2	GL2 terminal voltage	Vgl2	-5~Vcc	V	Vcc=18Vmax at GL2=-5V
3	U,V,W terminal Voltage	Vu,v,w	-5~600	V	
4	Supply voltage	Vcc	20	V	
5	Input voltage	Vin	-0.5~Vcc+0.5	V	
6	A-, AO terminal voltage	Va	-0.5~VB+0.5	V	
7	Fault terminal voltage	Vflt	-0.5~Vcc+0.5	V	
8	VB Supply Current	IBMAX	25	mA	
9	Operating Junction Temperature	Tjop	-20~125	°C	
10	Storage Temperature	Tstg	-40~150	°C	

Note 1 : Thermal resistance Rja

PACKAGE	FP-28DJ	UNIT
Single	121	°C/W
Mounted	84	°C/W
PCB size *	120x21x1.6 (30%)	(mm)

* This figure varies depending on the mounting condition.

3. Electrical Characteristics

Unless otherwise noted, Ta=25°C, Vu,v,w to GL1=374V, Vcc=15V. (suffix T=top, B=bottom arm)

No	ITEMS	SYMBOLS	MIN	TYP	MAX	UNIT	CONDITIONS
1	Supply Voltage	VCCop	13.5	15	16.5	V	
2	U, V, W terminal Voltage	Vuvwop	-3	374	450	V	
3	Stand-by current	Is1	-	4.3	10	mA	Vin=H or L, Between Vcc-GL1
		Is2	-	15	30	μA	Between VCU-U,V,VCV-V,VCW-W 15V, Vin=H or L
4	Input Voltage (Output is L)	VIH	3.5	-	-	V	Input=H or L
	Input Voltage (Output is H)	VIL	-	-	1.5	V	
5	Output Source Current	Io+	0.2	0.25	-	A	VCU-PGU, VCV-PGV,VCW-PGW=15V, Vcc-NGU, V, W =15V, PW≤10μs
6	Output Sink Current	Io-	0.4	0.5	-	A	PGU-U, PGV-V, PGW-W =15V, NGU,V,W -GL2=15V, PW≤10μs
7	High level Output Voltage	VOH	-	-	100	mV	VCU, V, W-PGU, V, W & Vcc-NGU, V, W, Vin=0V, Io=0A
8	Low level Output Voltage	VOL	-	-	100	mV	PGU, V, W-U,V,W & NGU,V,W-GL2 Vin=5V,Io=0A
9	Leakage Current at HV terminal	IL	-	-	50	μA	VCU,V,W=U,V,W=600V

ECN30531F

No	ITEMS	SYMBOLS	MIN	TYP	MAX	UNIT	CONDITIONS	
10	Input Current	IIL	-200	-	-	μA	Vin=0V Internal Pull up R=200kΩ	
11	Input Current	IIH	-120	-	-	μA	Vin=5V Internal Pull up R=200kΩ	
12	Vcc Under Voltage	Negative Going	Vuvb	9.5	10.5	11.6	V	
		Reset Hysterisis	Vrhb	0.1	0.4	0.9	V	
13	Vcu,v,w Under Voltage	Negative Going	Vuvt	8.9	10.5	12.1	V	
		Reset Hysterisis	Vrht	0.1	0.4	0.9	V	
14	OC Input Positive Going threshold	Voc	0.44	0.49	0.54	V		
15	Fault Output On Resistance	Ronf	-	300	400	Ω	F-GL1=0.5V	
16	Turn On Delay Time	tont	0.5	1.2	2.0	μs	CL=1000pF RL=0Ω	
17		tonb	0.5	1.2	2.0	μs	CL=1000pF RL=0Ω	
18	Turn Off Delay Time	tofft	0.5	1.2	2.0	μs	CL=1000pF RL=0Ω	
19		toffb	0.1	0.6	1.5	μs	CL=1000pF RL=0Ω	
20	Top/Bottom Output Delay Time Difference	deltat1	-0.5	0.1	1.0	μs	tofft-tonb	
21		deltat2	-1.0	-0.5	0	μs	toffb-tont	
22	OC Output Shutdown Delay	toc	-	1.3	1.7	μs	CL=1000pF RL=0Ω	
23	Fault Output Delay	tflt	-	0.6	1.6	μs	CL=1000pF RL=0Ω	
24	Fault Reset Delay Time	tfirs	6.5	10	20	μs	CL=1000pF RL=0Ω	
25	Minimum Input On Pulse Width (Top arm)	toptmin	0.4	0.7	1.2	μs	CL=1000pF RL=0Ω	
26	Fault Output Sink Current	lflt	4	-	-	mA	Vcc=15V,F-GL=2V	
27	Op-Amp Input Offset Voltage	Vos	-	-	30	mV		
28	Op-Amp High Level Output Voltage	VOHa	5	7.5	-	V		
29	Op-Amp Low Level Output Voltage	VOLa	-	-	20	mV		
30	Op-Amp Output Source Current	Isrca	1	-	-	mA		
31	Op-Amp Output Sink Current	Isnka	1	-	-	mA		
32	VB output Voltage	VB	6.8	7.5	8.2	V	Output current=0mA	
33	VB output current	IB	15	20	-	mA	Delta V Load=0.2V	

Note 1: Vuvb, Vrhb, Vuvt and Vrht are defined and shown in Fig. 1

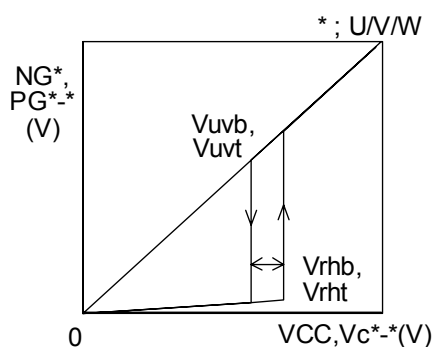

Fig 1. Negative going and reset voltage and hysteresis for the top and bottom arm under voltage circuit

ECN30531F

4. Truth Table

INPUT		OC Input	U phase		V phase		W phase		
			Top arm	Bot.arm	Top arm	Bot.arm	Top arm	Bot.arm	
SUT	L	L	ON	-	-	-	-	-	
	H		OFF	-	-	-	-	-	
SUB	L		-	ON	-	-	-	-	
	H		-	OFF	-	-	-	-	
SVT	L		-	-	ON	-	-	-	
	H		-	-	OFF	-	-	-	
SVB	L		-	-	-	ON	-	-	
	H		-	-	-	OFF	-	-	
SWT	L		-	-	-	-	ON	-	
	H		-	-	-	-	OFF	-	
SWB	L		-	-	-	-	-	ON	
	H		-	-	-	-	-	OFF	
-	-		H	OFF	OFF	OFF	OFF	OFF	OFF
SUT,SUB	L		-	OFF	OFF	-	-	-	-
SVT,SVB	L		-	-	-	OFF	OFF	-	-
SWT,SWB	L		-	-	-	-	-	OFF	OFF

Note 1: Fault output level is referenced Low when over current or under voltage for Vcc is detected.

Note 2: Over current protection works when the voltage drop of the external sensing resistor exceeds the threshold voltage Voc. In this case all six outputs are turned off and Fault output level becomes low.

Reset after detection is done by feeding high signal to all six inputs or re-supplying Vcc voltage.

Note 3: The output signal for Fault is reset by feeding high signal to all six inputs.

ECN30531F

5. Definition of switching delay

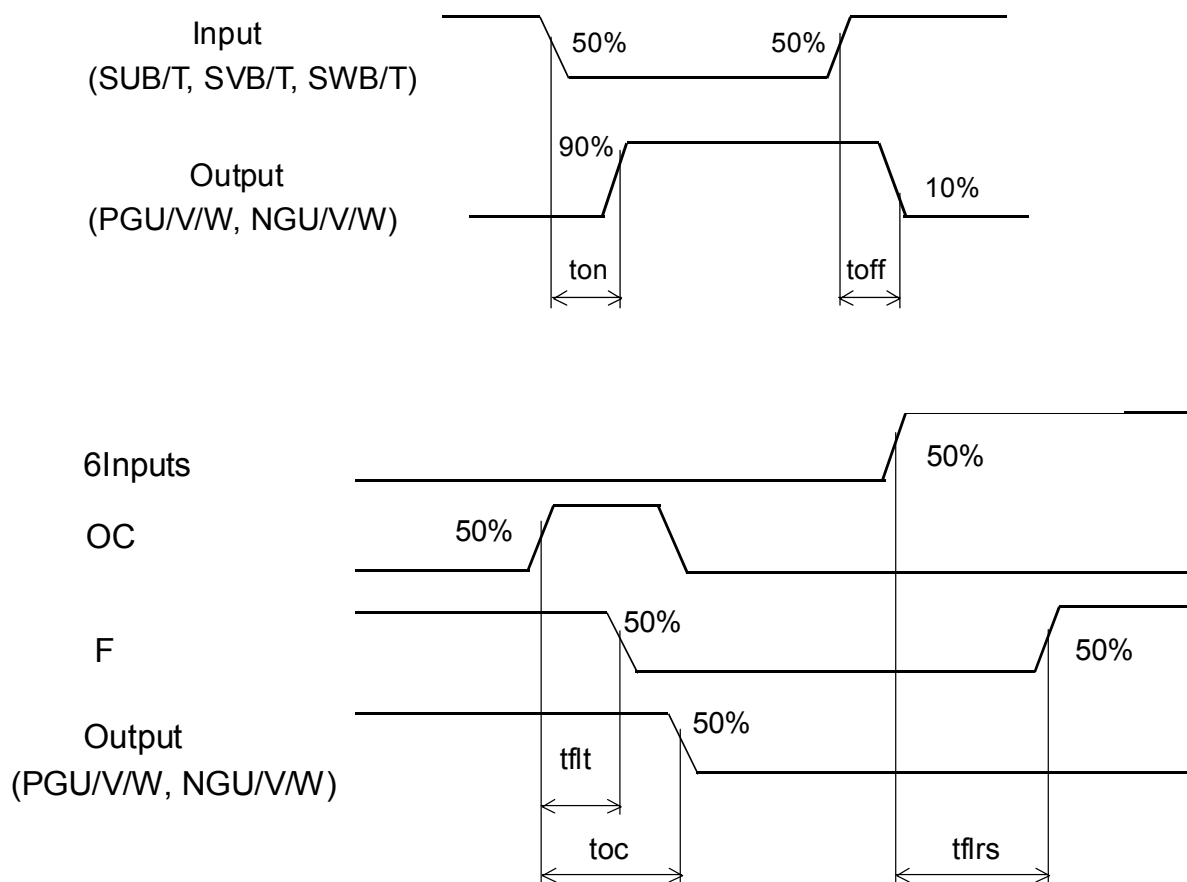

6. Standard Application

No.	ITEMS	SYMBOLS	VALUES TOL.	UNIT	CONDITIONS
1	PWM Frequency	fpwm	1 ~ 20	kHz	
2	VB Smoothing Capacitor	Co	0.22 ± 20%	μF	Stress voltage:VB
3	Boot Strap Capacitor	Cb	3.3 ± 20%	μF	Stress voltage:Vcc
4	Boot Strap Diodes	Db	Hitachi DFG1C6 DFM1F6 or equivalent	-	600V/1.0A trr ≤ 0.1μs
5	Sensing Resistor	Rs	Note 1	Ω	
6	OC Filtering Resistor	R1	1.0	kΩ	Note 2
7	OC Filtering Capacitor	C1	1000	pF	Note 2
8	Load resistor for F terminal	Rf	5.6 ± 20%	kΩ	

Note 1. Over-current detection level is determined by the following equation

$$I_{oc} = V_{oc} / R_s \text{ (A)}$$

Note 2. This IC has filters of 0.4μs for noise reduction.
 However, appropriate R1, C1 should be adjusted when noise cannot be removed.

ECN30531F

7. Pin Assignment

1	VCC	VCU	28
2	SUT	PGU	27
3	SVT	U	26
4	SWT	N.C	25
5	SUB	VCV	24
6	SVB	PGV	23
7	SWB	V	22
8	F	VCW	21
9	OC	PGW	20
10	CB	W	19
11	AO	N.C	18
12	A-	NGU	17
13	GL1	NGV	16
14	GL2	NGW	15

8. Pin Definitions

Pin #	Symbol	Pin Definition
1	Vcc	External Analog Power Supply (15VDC +/- 10%)
2	SUT	Phase U TOP Arm control signal (CMOS logic input)
3	SVT	Phase V TOP Arm control signal (CMOS logic input)
4	SWT	Phase W TOP Arm control signal (CMOS logic input)
5	SUB	Phase U BOTTOM Arm control signal (CMOS logic input)
6	SVB	Phase V BOTTOM Arm control signal (CMOS logic input)
7	SWB	Phase W BOTTOM Arm control signal (CMOS logic input)
8	F	Fault output signal reports OC and LOW Vcc conditions
9	OC	Over Current detection (analog input) from external Sense Resistor
10	CB	Internally regulated (VB) 7.5V Output Pin (External 15mA guarantee)
11	AO	Op-Amp (AO) Output voltage
12	A-	Op-Amp (A-) input voltage
13	GL1	Analog ground
14	GL2	Op-Amp (A+) input voltage
15	NGW	Phase W BOTTOM Arm gate drive Push-Pull output
16	NGV	Phase V BOTTOM Arm gate drive Push-Pull output
17	NGU	Phase U BOTTOM Arm gate drive Push-Pull output
18	NC	No Connection
19	W	Phase W TOP Arm return ("ground") reference rail
20	PGW	Phase W TOP Arm gate drive Push-Pull output
21	VCW	Phase W TOP Arm Boot Strap summing point via external capacitor Cb
22	V	Phase V TOP Arm return ("ground") reference rail
23	PGV	Phase V TOP Arm gate drive Push-Pull output
24	VCV	Phase V TOP Arm Boot Strap summing point via external capacitor Cb
25	NC	No Connection
26	U	Phase U TOP Arm return ("ground") reference rail
27	PGU	Phase U TOP Arm gate drive Push-Pull output
28	VCU	Phase U TOP Arm Boot Strap summing point via external capacitor Cb

ECN30531F

9. Outline Drawing

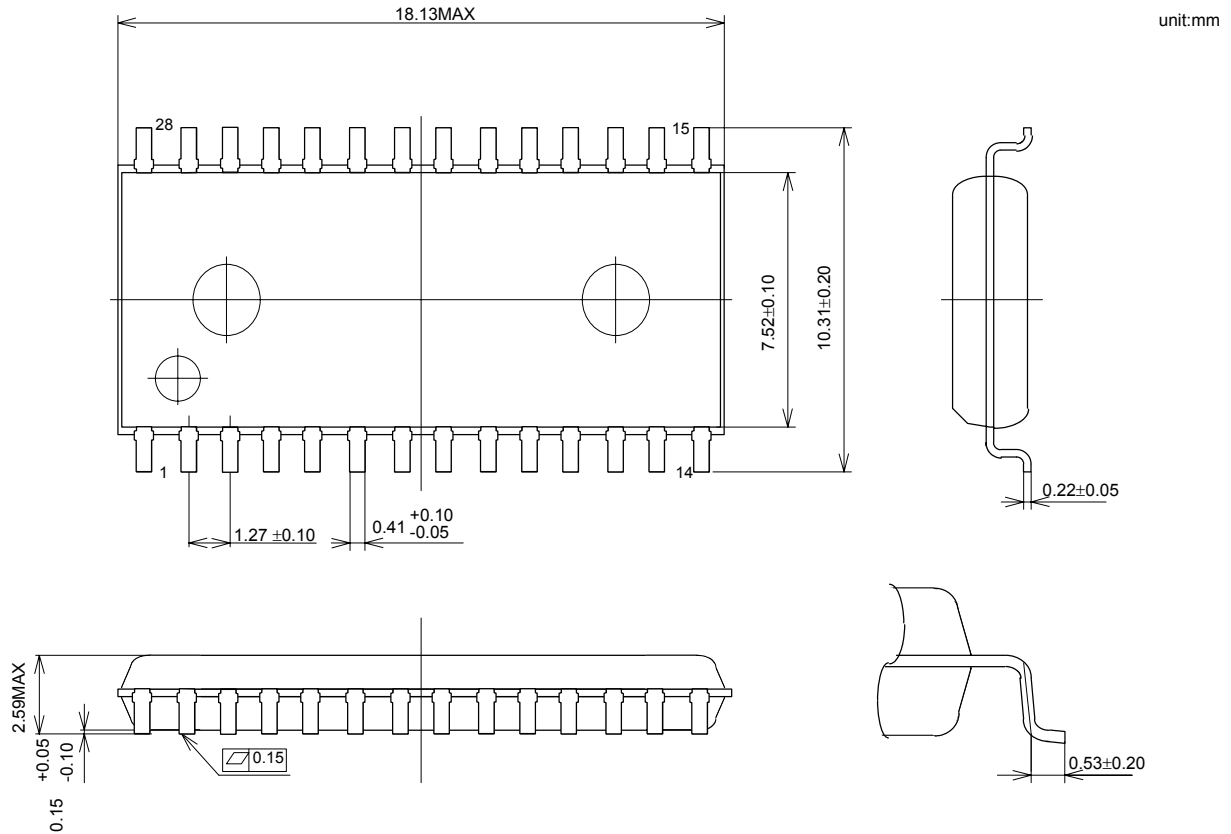

10. Marking

10.1 Marking Position

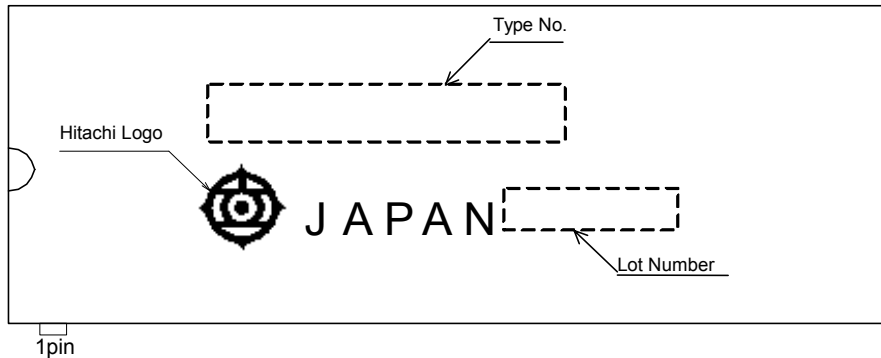

10.2 Marking contents

1) Type No.

ECN 30531F

Series name
Hitachi High-Voltage IC

2) Lot Number

6 C 15F

Quality control number.
Numerals from 1 to 99, alphabetical character except O & I or space is used.
Last character "F" means lead(PB)-free.
Assembled month as shown in below.
Jan. ; A Feb. ; B March ; C April ; D May ; E June ; K
July ; L Aug. ; M Sept. ; N Oct. ; X Nov. ; Y Dec. ; Z
First digit of Assembled year (A.D.)

3) Method of marking: Ink Marking

HITACHI

ECN30531F

11. Packaging

11.1 Magazine packing

IC packaging method is shown below. IC is packed with magazine, inner box and outer box.

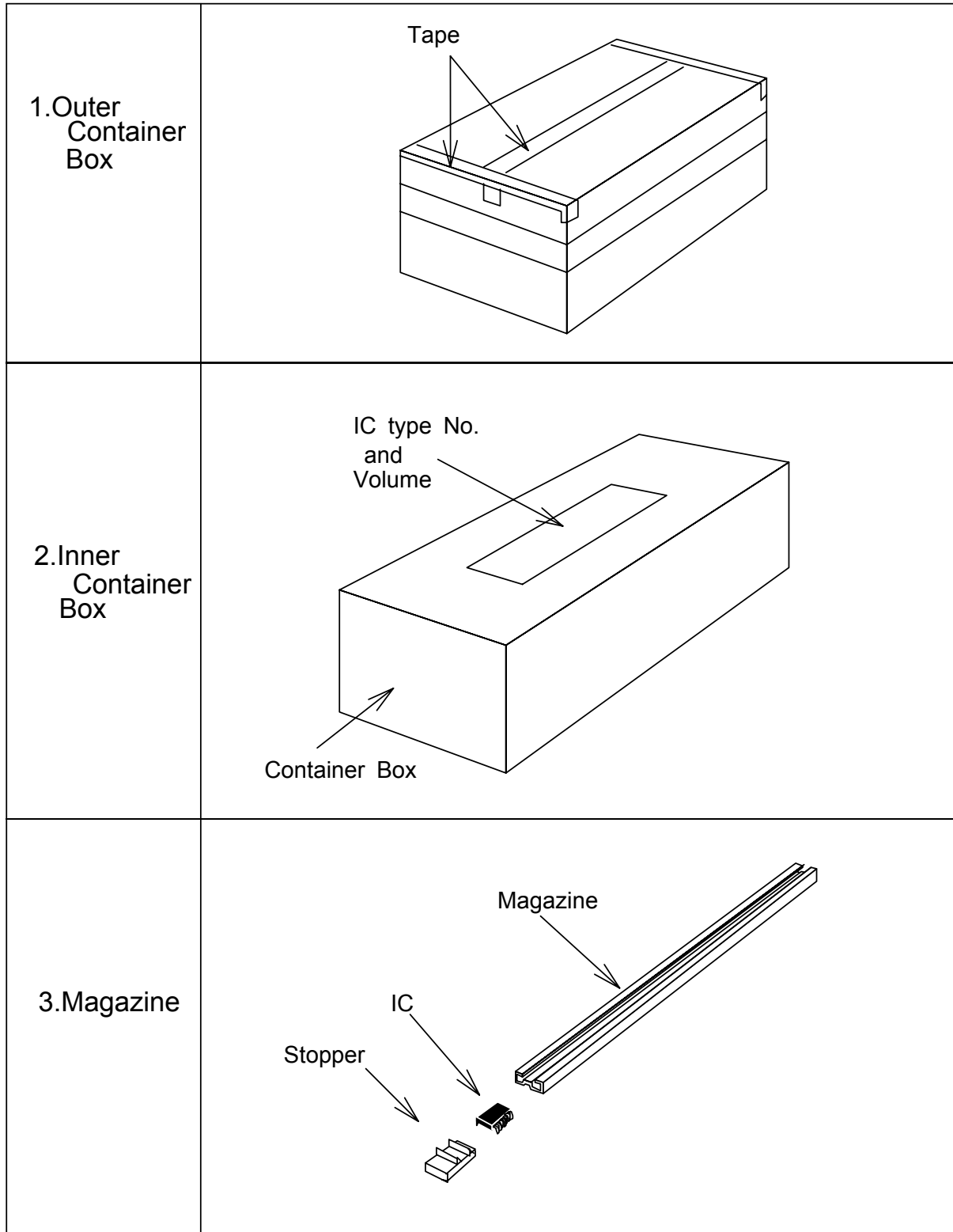

ECN30531F

11.2 Reel packing

IC packing method is shown below. IC is taped and reeled in inner box, wrapped by outer cardboard box.

1. Outer and inner packing box

carton tape

Label (IC type No. and Quantity printed)

Tape

Outer box Cardboard Inner box

2. Tape and Reel

Embossed Tape Specifications

Tape Dimensions

Explanatory Drawing for Structure

Metal mold NO. KEY-234

型名	Ao	Bo	W	F	E	P1	P2	Po	Do	T	Ko	D1	T1
TE2416	10.8	18.2	24.0	11.5	1.75	16.0	2.0	4.0	1.50	0.3	3.3	2.0	6.5
	+0.1	+0.1	+0.3	+0.1	+0.1	+0.1	+0.1	+0.1	+0.1	±	+0.1	MIN	MAX
	-0.1	-0.1	-0.3	-0.1	-0.1	-0.1	-0.1	-0.1	-0	0.05	-0.1		

Unit:mm

- (1) Embossed tape is article antistatic treatment.
- (2) Embossed tape is made with vinyl chloride of conductive type.
- (3) Permissible error of the feedhole cumulative pitch is ±0.3mm/50pitch.
- (4) The R measurement without indication is 0.3mm max.
- (5) Packing quantity of IC is max 1000 IC/reel.

Reel Specifications

IC TYPE No.

Unit:mm

Both reel plates and core is made with plastic of conductive type.

TAPE SIZE	A	N	W1	W2
24	330	100	25.5	29.5
	+2.0	+1.0	+0.5	+1.0
	-2.0	-1.0	-0.5	-1.0

(Note) The actual reels may be somewhat different from the image of the drawing but are to have the same dimension as above.

HITACHI

PDE-30531-1
Ref. No. IC-SP-05059 R1

ECN30531F

12. Inspection

Hundred percent inspections shall be conducted on electric characteristics at room temperature.

13. Cautions

13.1 Customers are advised to follow the below cautions to protect semiconductor from electrical static discharge (ESD).

- a) IC needs to be dealt with caution to protect from damage by ESD. Material of container or any device to carry semiconductor devices should be free from ESD, which may be caused by vibration while transportation. To use electric-conductive container or aluminum sheet is recommended as an effective countermeasure.
- b) What touches semiconductor devices such as work platform, machine and measuring and test equipment should be grounded.
- c) Workers should be grounded connecting with high impedance around 100k Ω to 1M Ω while dealing with semiconductor to avoid damaging IC by electric static discharge.
- d) Friction with other materials such as a high polymer should not be caused.
- e) Attention is needed so that electric potential will be kept on the same level by short circuit terminals when PC board with mounted IC is carried and that vibration or friction might not occur.
- f) Air conditioning is needed so that humidity should not drop.

13.2 Applying molding or resin coating is recommended for below mentioned pin-to-pin insulation; 17-19, 21-22, 24-26

13.3 Refer to "Precautions for Use of High-Voltage Monolithic ICs" for the other precautions and instructions on how to deal with products.

13.4 Regardless of changes in external conditions during use, "absolute maximum ratings" should never be exceeded in designing electronic circuits that employ products. In a case absolute maximum ratings are exceeded, products may be damaged or destroyed. In no event shall Hitachi be liable for any failure in products or any secondary damage resulting from use at a value exceeding the absolute maximum ratings.

13.5 Products may experience failures due to accident or unexpected surge voltages. Accordingly, adopt safe design features, such as redundancy or prevention of erroneous action, to avoid extensive damage in the event of a failure.

13.6 Products are not designed, manufactured, or warranted to be suitable for use where extremely high reliability is required (such as use in nuclear power control, aerospace and aviation, traffic equipment, life-support-related medical equipment, fuel control equipment and various kinds of safety equipment). Inclusion of products in such application shall be fully at the risk of customers.

Hitachi, Ltd. assumes no liability for applications assistance, customer product design, or performance. In such cases, it is advised customers to ensure circuit and/or product safety by using semiconductor devices that assures high reliability or by means of user's fail-safe precautions or other arrangement. (If a semiconductor device fails, there may be cases in which the semiconductor device, wiring or wiring pattern will emit smoke or cause a fire or in which the semiconductor device will burst.)

ECN30531F

13.7 The figure below shows recommended mounting condition by the reflow.
Reflow to "Precautions for Use of High-Voltage Monolithic ICs" for details.

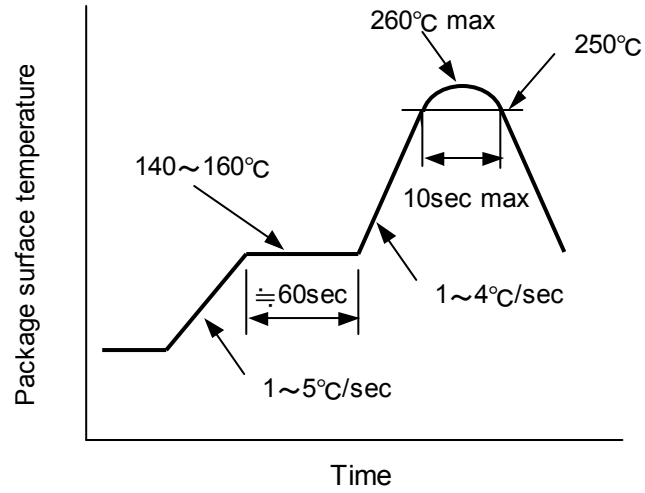

Infrared reflow and air reflow Recommended condition

ECN30531F

14. Important Notices

- 14.1 Hitachi warrants performance of its power semiconductor products (hereinafter called “products”) to the specifications applicable at the time of sale in accordance with the Product Specification.
- Testing and other quality control techniques are utilized to the extent Hitachi needs to meet specifications described in the Product Specification. Specific testing of all parameters of each device is not necessarily performed, except those mandated by related laws and/or regulations.
- 14.2 Should any claim be made within one month of product delivery about products’ failure to meet performance described in the Product Specification, all the products in relevant lot(s) shall be re-tested and re-delivered. Products delivered more than one month before of such claim shall not be counted for such response.
- 14.3 Hitachi assumes no obligation or any way of compensation should any fault about customer’s goods using products be found in marketplace. Only in such a case fault of Hitachi is evident and products concerned do not meet the Product Specification, compensation shall be conducted if claimed within one year of product delivery up to in the way of product replacement or payment of equivalent amount.
- 14.4 Hitachi reserves the right to make changes in the Product Specification and to discontinue mass production of the relevant products without notice. Customers are advised before purchasing to confirm specification of the product of inquiry is the latest version and that the relevant product is on mass production status in such a case purchasing is suspended for one year or more.
- 14.5 In no event shall Hitachi be liable for any damage that may result from an accident or any other cause during operation of the user’s units according to this Product Specification. Hitachi assumes no responsibility for any intellectual property claims or any other problems that may result from applications of information, products or circuits described in this Product Specification.
- 14.6 No license is granted by this Product Specification under any patents or other rights of any third party or Hitachi, Ltd.
- 14.7 This Product Specification may not be reproduced or duplicated, in any form, in whole or in part, without the expressed written permission of Hitachi, Ltd.
- 14.8 The products (technologies) described in this Product Specification are not to be provided to any party whose purpose in their application will hinder maintenance of international peace and safety nor are they to be applied to that purpose by their direct purchasers or any third party. When exporting these products (technologies), the necessary procedures are to be taken in accordance with related laws and regulations.

Precautions for Safe Use and Notices

If semiconductor devices are handled in inappropriate manner, failures may result. For this reason, be sure to read "Precaution for Use" before use.



This mark indicates an item about which caution is required.



CAUTION

This mark indicates a potentially hazardous situation which, if not avoided, may result in minor or moderate injury and damage to property.



CAUTION

(1) Regardless of changes in external conditions during use "absolute maximum ratings" should never be exceeded in designing electronic circuits that employ semiconductors.

In the case of pulse use, furthermore, "safe operating area (SOA)" precautions should be observed.

(2) Semiconductor devices may experience failures due to accident or unexpected surge voltages. Accordingly, adopt safe design features, such as redundancy or prevention of erroneous action, to avoid extensive damage in the event of a failure.

(3) In cases where extremely high reliability is required (such as use in nuclear power control, aerospace and aviation, traffic equipment, life-support-related medical equipment, fuel control equipment and various kinds of safety equipment), safety should be ensured by using semiconductor devices that feature assured safety or by means of user's fail-safe precautions or other arrangement. Or consult Hitachi's sales department staff.

(If a semiconductor device fails, there may be cases in which the semiconductor device, wiring or wiring pattern will emit smoke or cause a fire or in which the semiconductor device will burst)

NOTICES

1. This Data Sheet contains the specifications, characteristics (in figures and tables), dimensions and handling notes concerning power semiconductor products (hereinafter called "products") to aid in the selection of suitable products.
2. The specifications and dimensions, etc. stated in this Data Sheet are subject to change without prior notice to improve products characteristics. Before ordering, purchasers are advised to contact Hitachi's sales department for the latest version of this Data Sheet and specifications.
3. In no event shall Hitachi be liable for any damage that may result from an accident or any other cause during operation of the user's units according to this Data Sheet. Hitachi assumes no responsibility for any intellectual property claims or any other problems that may result from applications of information, products or circuits described in this Data Sheet.
4. In no event shall Hitachi be liable for any failure in a semiconductor device or any secondary damage resulting from use at a value exceeding the absolute maximum rating.
5. No license is granted by this Data Sheet under any patents or other rights of any third party or Hitachi, Ltd.
6. This Data Sheet may not be reproduced or duplicated, in any form, in whole or in part, without the expressed written permission of Hitachi, Ltd.
7. The products (technologies) described in this Data Sheet are not to be provided to any party whose purpose in their application will hinder maintenance of international peace and safety nor are they to be applied to that purpose by their direct purchasers or any third party. When exporting these products (technologies), the necessary procedures are to be taken in accordance with related laws and regulations.