

ECN30108

1. Product Description

1.1 Description

- Maximum Ratings: 250VDC/1.4A, suitable for the system from 100VAC to 115VAC.
- Drives a motor using high voltage PWM (Pulse Width Modulation) control and increases efficiency for energy saving.
- Latch-up free monolithic IC using a high voltage Dielectric Isolation (DI) technology.
- Reduces space due to a single chip, able to be embedded in a motor.
- Drives a motor using a high voltage DC power supply and a low voltage DC power supply.

1.2 Functions and Features

- Hall elements applicable (Hall amplifiers are embedded)
- Built-in high voltage diodes for charge pump
- Built-in motor rotational speed monitor circuit (FG: Frequency Generator)
- Power on/off sequence free
- Built-in all output IGBT shut-off function
- Built-in over-current detection
- Built-in VCC low-voltage detection
- Built-in three-phase bridge consisting of six IGBTs and six FWDs (Free-Wheeling Diodes)
- Built-in PWM and three-phase distributor circuits for 20kHz PWM operation
- Variable speed control by an analog signal at VSP pin

1.3 Block Diagram

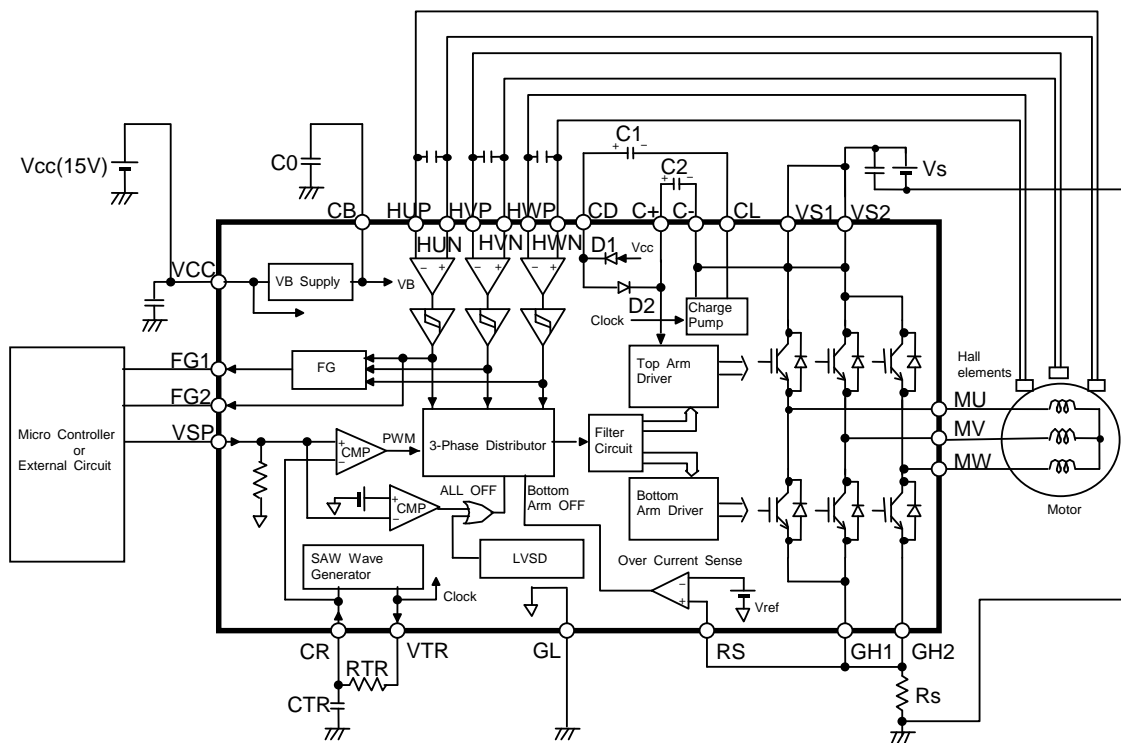
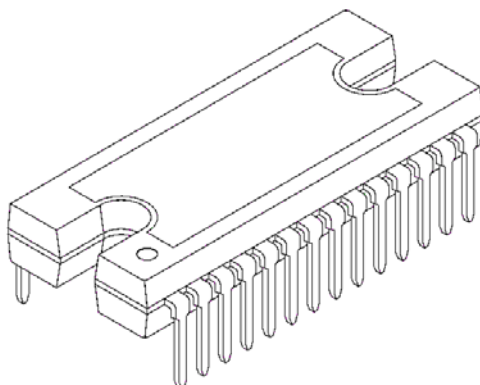

FIGURE 1.3.1 Block Diagram (ECN30108 is shown inside the bold line)

ECN30108

1.4 Package



ECN30108P
(Package: DIP28H)

FIGURE 1.4.1 Type and Package of ECN30108

ECN30108

2. Specification

2.1 Absolute Maximum Ratings

TABLE 2.1.1 Absolute Maximum Ratings

Condition: Ta=25°C

No.	Item	Symbol	Pin	Rating	Unit	Condition
1	Output device breakdown voltage	VSM	VS1, VS2, CL, CD, MU, MV, MW	250	V	
2	VCC power supply voltage	VCC	VCC	18	V	
3	Voltage between C+ and C-	VCPM	C+, C-	18	V	
4	Input voltage	VIN	VSP, RS, HUP, HUN, HVP, HVN, HWP, HWN	-0.5 to VB+0.5	V	
5	Output current	Pulse	IP	MU, MV, MW	A	Note 1
6		DC				
7	VB supply output current	IBMAX	CB	50	mA	
8	Junction operating temperature	Tjop	—	-20 to +135	°C	Note 2
9	Storage temperature	Tstg	—	-40 to +150	°C	

Note 1 : Output IGBTs can handle this peak current at 25°C junction operating temperature.

Note 2 : Thermal resistance

Between junction and case (tab): Rjc=3°C/W (Reference value)

Note 3 : This IC can withstand 305V within 1 minute.

ECN30108

2.2 Electrical Characteristics

TABLE 2.2.1 Electrical Characteristics Suffix (T: Top arm, B: Bottom arm) Condition: Ta=25°C

No.	Item	Symbol	Pin	Min.	Typ.	Max.	Unit	Condition	
1	Standby current	ISH	VS1, VS2	—	0.3	0.5	mA	VSP=0V, VS=141V, VCC=15V	
2		ICC	VCC	—	3	10	mA	VSP=0V, VCC=15V, IB=0A	
3	IGBT collector-emitter saturation voltage	VONT	MU, MV, MW	—	2.0	3.0	V	I=0.7A, VCC=15V	
4		VONB		—	2.0	3.0	V	I=0.7A, VCC=15V	
5		VFDT		—	1.7	2.5	V	I=0.7A	
6	Free-wheeling diode forward voltage	VFDB		—	1.7	2.5	V		
7	VTR output resistance	RVTR	VTR	—	200	400	Ω	IVTR=±1mA, VCC=15V	
8	SAW wave	High/Low level	CR	4.9	5.4	6.1	V	VCC=15V	
9		VSAWL		1.7	2.1	2.5	V	Note 1	
10		Amplitude		VSAWW	2.8	3.3	3.8	V	VCC=15V Note 2
11	Over-current detection reference voltage	Vref	RS	0.45	0.50	0.55	V	VCC=15V	
12	Over-current detection shutdown delay time	Tref	RS	—	5.0	6.5	μs	VCC=15V	
13	Hall signal input	Minimum differential voltage	HUP, HUN, HVP, HVN, HWP, HWN	60	—	—	mVp-p	VCC=15V Note 3	
14		Current		IH	—	—	2	μA	
15		Common mode voltage range		VHCM	3	—	VB	V	
16		Hysteresis		VHHYS	20	40	60	mV	
17		Voltage L→H		VHLH	-5	20	45	mV	
18		Voltage H→L		VHHL	-45	-20	5	mV	
19	VSP input	Current	VSP	5	—	50	μA	VSP=5.0V, VCC=15V Pull-down resistor Note 4	
20		Offset voltage		SPCOMOF	-40	10	60	mV	VCC=15V, Voltage from CR pin
21		All off operating voltage		Voff	0.85	1.23	1.60	V	VCC=15V
22	VB supply output	Voltage	CB	6.8	7.5	8.2	V	VCC=15V, IB=0A	
23		Current		IB	—	—	45	mA	VCC=15V
24	FG1, FG2 output resistance	RFGP	FG1, FG2	—	1.5	3.0	kΩ	IFG=1mA, VCC=15V Note 5	
25		RFGN		—	0.7	1.5	kΩ	IFG=-1mA, VCC=15V	
26	LVSD	Operating voltage	VCC, MU, MV, MW	11.0	12.0	12.9	V	Note 6	
27		Recovery voltage		LVSDOFF	11.1	12.5	13.0	V	
28		Hysteresis		Vrh	0.1	0.5	0.9	V	
29	RS input current	IILRS	RS	-100	—	—	μA	VCC=15V, RS=0V Note 7	
30	Minimum pulse width (bottom arms)	TMINB	MU, MV, MW	0.8	—	—	μs	VCC=15V Note 8	
31	Charge pump diode forward voltage	VFDCP	VCC, CD, C+	—	1.0	1.4	V	I=1mA	

Note 1. See Standard Applications (section 3 at page 8) to set the SAW wave frequency.

Note 2. The amplitude of SAW wave (i.e., VSAWW) is determined by the following equation.

$$VSAWW = VSAWH - VSAWL$$

Note 3. The equivalent circuit is shown in FIGURE 2.2.1.

Note 4. Internal pull-down resistor is typically 200kΩ. The equivalent circuit is shown in FIGURE 2.2.2.

Note 5. The equivalent circuit is shown in FIGURE 2.2.3.

Note 6. The LVSD (Low Voltage Shut Down) function detects and shuts down at low VCC.

Note 7. Internal pull-up resistor is typically 200kΩ. The equivalent circuit is shown in FIGURE 2.2.4.

Note 8. The minimum pulse width to be able to turn on and off bottom arms.

ECN30108

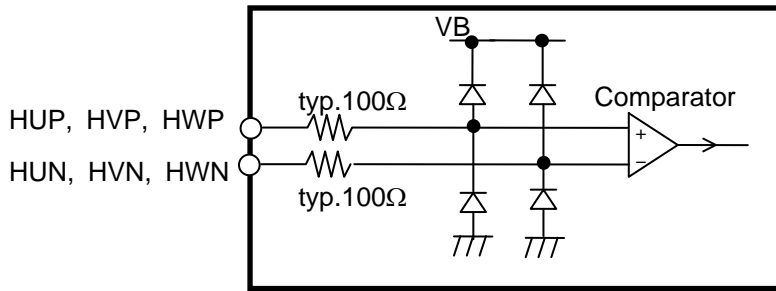

FIGURE 2.2.1 Equivalent Circuit around Hall Signal Pins

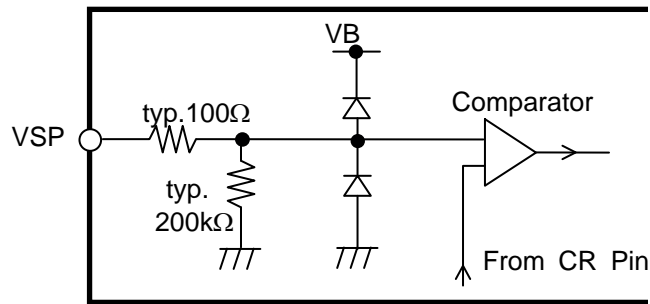

FIGURE 2.2.2 Equivalent Circuit around VSP Pin

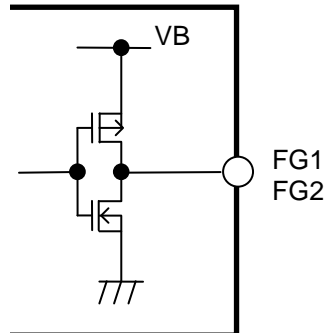

FIGURE 2.2.3 Equivalent Circuit around FG1, FG2 Pins

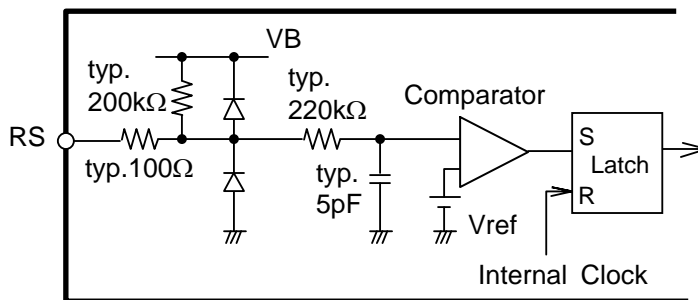

FIGURE 2.2.4 Equivalent Circuit around RS Pin

2.3 Operating Condition

TABLE 2.3.1 Operating Condition

No.	Item	Symbol	Pin	Min.	Typ.	Max.	Unit
1	Supply voltage	VSop	VS1, VS2	15	—	185	V
2		VCCop	VCC	13.5	15	16.5	V

ECN30108

2.4 Functions and Operations

2.4.1 Truth Table

TABLE 2.4.1.1 Truth Table

Mode	Hall signal input			Phase-U		Phase-V		Phase-W		FG1 output	FG2 output
	HU	HV	HW	Top arm	Bottom arm	Top arm	Bottom arm	Top arm	Bottom arm		
(1)	H	L	H	OFF	ON	ON	OFF	OFF	OFF	H	H
(2)	H	L	L	OFF	ON	OFF	OFF	ON	OFF	L	H
(3)	H	H	L	OFF	OFF	OFF	ON	ON	OFF	H	H
(4)	L	H	L	ON	OFF	OFF	ON	OFF	OFF	L	L
(5)	L	H	H	ON	OFF	OFF	OFF	OFF	ON	H	L
(6)	L	L	H	OFF	OFF	ON	OFF	OFF	ON	L	L
—	L	L	L	OFF	OFF	OFF	OFF	OFF	OFF	L	L
—	H	H	H	OFF	OFF	OFF	OFF	OFF	OFF	H	H

Note: Inputs H: Input voltage between H*P and H*N > VHLH
 Inputs L: Input voltage between H*P and H*N < VHHL

2.4.2 Timing Chart

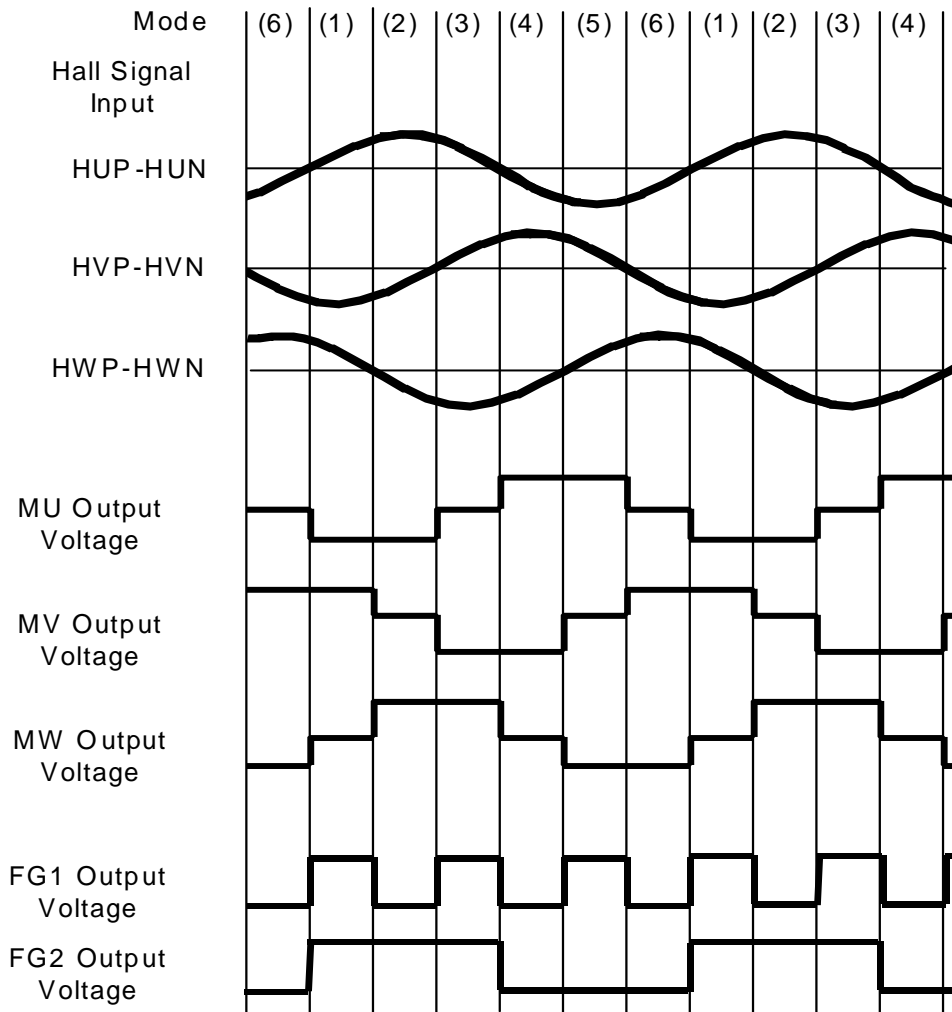

FIGURE 2.4.2.1 Timing Chart

ECN30108

2.4.3 PWM Operation

The PWM signal is generated by comparing the input voltage at the VSP pin with an internal SAW wave voltage (available at the CR pin). The relation between VSP pin voltage and PWM duty is shown in FIGURE 2.4.3.1. The PWM is operated by bottom arms.

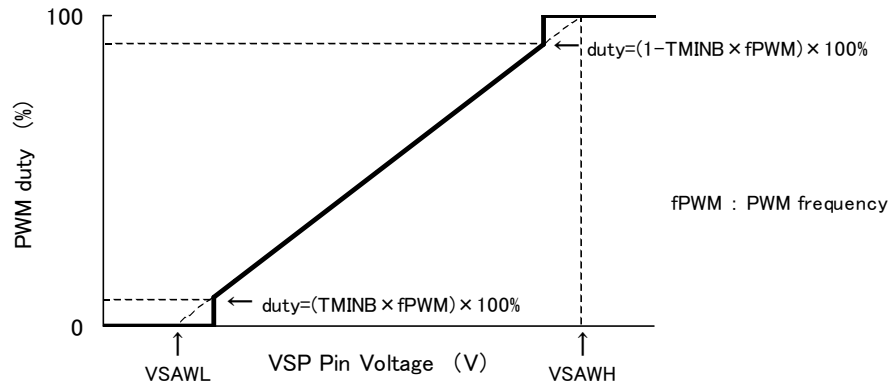

FIGURE 2.4.3.1 Relation between VSP Input Voltage and PWM Duty

2.4.4 Over Current Detection

Over-current is monitored using an external resistance RS. When the input voltage at the RS pin exceeds the internal reference voltage (Vref, typ. 0.5V), all bottom arm IGBTs are turned off. Reset is automatically operated at each period of internal clock (available at VTR pin).

2.4.5 VCC Low-Voltage Detection

When VCC voltage drops below operating voltage (LVSDON, typ. 12.0V), all IGBTs (top and bottom arms) are turned off. When VCC voltage goes up, this all-off state is reset at the recovery voltage (LVSDOFF, typ. 12.5V).

2.4.6 All Output IGBT Shutoff Function

When VSP drops below Voff (typ. 1.23V), all IGBTs (top and bottom arms) are shut off.

TABLE 2.4.6.1 Output Status to VSP Input Voltage

VSP Input Voltage	Top Arm Output	Bottom Arm Output
$0V \leq VSP < Voff$	All IGBTs are OFF	All IGBTs are OFF
$Voff \leq VSP < VSAWL$	Based on TABLE 2.4	All IGBTs are OFF
$VSP \geq VSAWL$	Based on TABLE 2.4	Based on TABLE 2.4

Note: When a motor is rotating and VSP drops below Voff, the VS voltage can rise. Also in this condition VS must not exceed the 250VDC breakdown voltage.

ECN30108

3. Standard Applications

3.1 External Components

TABLE 3.1.1 External Components

Component	Standard value	Usage	Remark
C0	1.0μF ± 20%	Smooths the internal power supply (VB)	Stress voltage is VB (=8.2V)
C1, C2	1.0μF ± 20%	For charge pump	Stress voltage is VCC
Rs	Note 1	Sets over-current detection	
CTR	1800pF ± 5%	Sets PWM frequency	Stress voltage is VB (=8.2V) Note 2
RTR	22kΩ± 5%	Sets PWM frequency	Stress voltage is VB (=8.2V) Note 2

Note 1 The detection current (IO) can be calculated as follows.

$$IO (A) = Vref (V) / Rs (\Omega)$$

To determine the sense resistor Rs, see the section 4 in Appendix.

Note 2. The PWM frequency is approximated by the following equation.

$$PWM \text{ frequency (Hz)} \approx 0.494 / (CTR (F) \times RTR (\Omega))$$

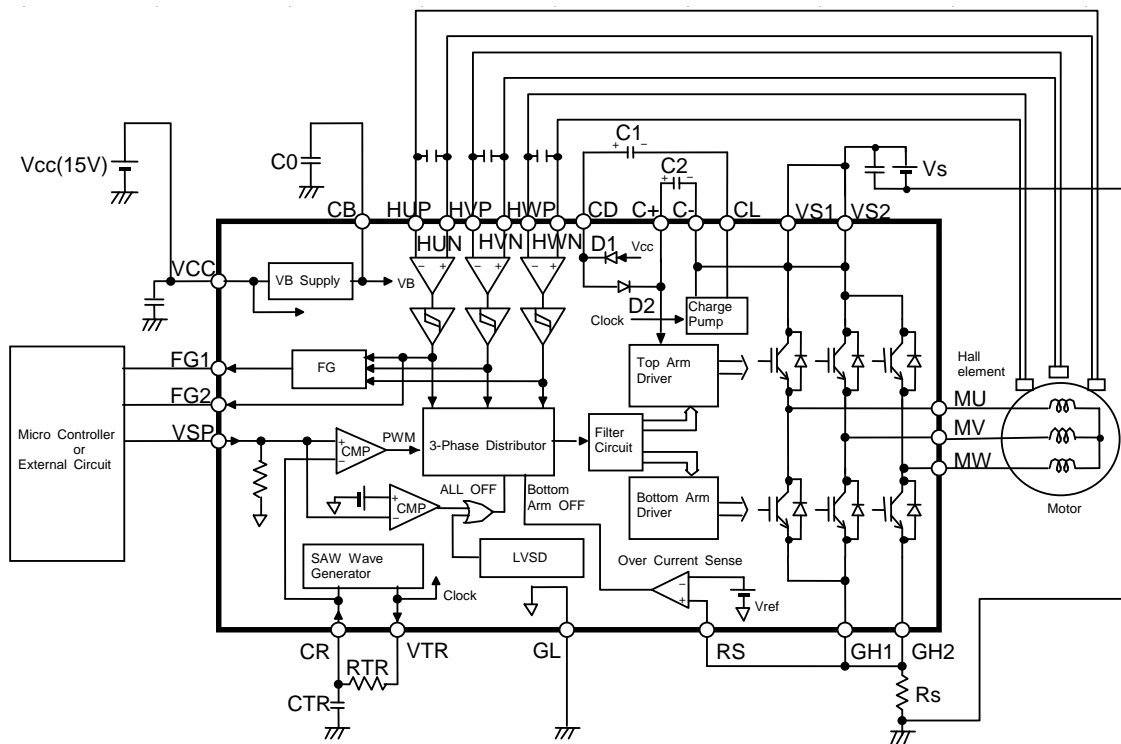

FIGURE 3.1.1 Block Diagram (ECN30108 is shown inside the bold line.)

ECN30108

4. Pin Locations

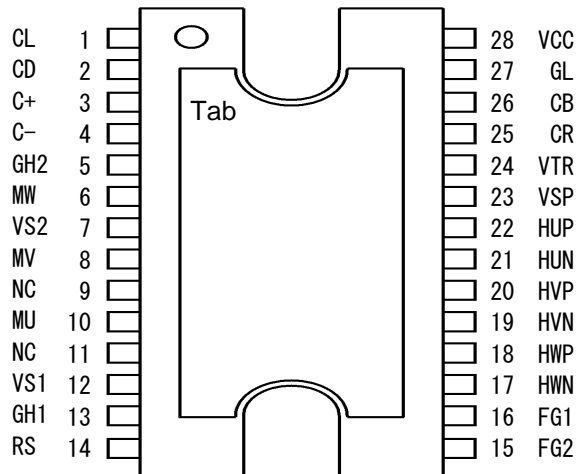

FIGURE 4.1 Pin Locations

5. Explanations of Pins

TABLE 5.1 Explanations of Pins

Pin No.	Symbol	Explanation	Remark
1	CL	For the charge pump circuit	Note1
2	CD	For the charge pump circuit	Note1
3	C+	For the charge pump circuit, power supply pin for top arm drive circuit	Note1
4	C-	For the charge pump circuit	Note1, Note2
5	GH2	Emitter of W phase bottom arm IGBT and anode of W phase bottom arm FWD.	Note3
6	MW	W phase output	Note1
7	VS2	Power supply for top arm IGBTs of V and W phases	Note1, Note2
8	MV	V phase output	Note1
9	NC	No connection	Note4
10	MU	U phase output	Note1
11	NC	No connection	Note4
12	VS1	Power supply for top arm IGBT of U phase	Note1, Note2
13	GH1	Emitters of U and V phase IGBTs and anodes of U and V phase FWDs.	Note3
14	RS	Input for over-current detection	
15	FG2	Output for motor rotational speed monitor (one pulse / 360 electrical degrees)	
16	FG1	Output for motor rotational speed monitor (three pulses / 360 electrical degrees)	
17	HWN	W phase Hall signal minus input	
18	HWP	W phase Hall signal plus input	
19	HVN	V phase Hall signal minus input	
20	HVP	V phase Hall signal plus input	
21	HUN	U phase Hall signal minus input	
22	HUP	U phase Hall signal plus input	
23	VSP	Motor speed control analog signal input	
24	VTR	Connect a resistor to set the PWM frequency	
25	CR	Connect a resistor and a capacitor to set the PWM frequency	
26	CB	VB power supply output	
27	GL	Analog/Logic ground	
28	VCC	Analog/Logic power supply	

Note1 High voltage pin

Note2 The VS1, VS2 and C- pins are connected within the IC but VS1 and VS2 must also be connected by external wiring.

Note3 GH1 and GH2 are not connected within the IC and must be connected by external wiring.

Note4 Not connected to the internal IC chip.

ECN30108

6. Inspection

Hundred percent inspection shall be conducted on electric characteristics at room temperature.

7. Cautions

7.1 Installation

Tab (see FIGURE 4.1) should not be soldered.

Screws or clinchers should not be used to set IC on heat sink or such.

7.2 Countermeasures against Electrical Static Discharge (ESD)

(a) IC needs to be dealt with caution to protect from damage by ESD. Material of container or any device to carry semiconductor devices should be free from ESD, which may be caused by vibration while transportation. To use electrically conductive container or aluminum sheet is recommended as an effective countermeasure.

(b) What touches semiconductor devices such as work platform, machine and measuring and test equipment should be grounded.

(c) Workers should be grounded connecting with high impedance around 100k Ω to 1M Ω while dealing with semiconductor to avoid damaging IC by electric static discharge.

(d) Friction with other materials such as a high polymer should not be caused.

(e) Attention is necessary so that electric potential will be kept on the same level by short circuit pins when PC board with mounted IC is carried and that vibration or friction might not occur.

(f) The humidity at assembly line to mount IC on circuit boards should be kept around 45 to 75 percents using humidifiers or such. If the humidity can not be controlled sufficiently, using neutralization apparatus such as ionizers are effective.

7.3 Insulation between Pins

Applying molding or resin coating is recommended for below mentioned pin-to-pin insulation;
2-3, 4-5, 5-6, 6-7, 7-8, 12-13

7.4 Output Short-Circuit Protection

Protective function against short circuit (ex. load short, line-to-ground short or top/bottom arm short) is not built in this IC. External protection needs to prevent IC breakdown.

7.5 Absolute Maximum Ratings

Regardless of changes in external conditions during use, "absolute maximum ratings" should never be exceeded in designing electronic circuits that employ products. In a case absolute maximum ratings are exceeded, products may be damaged or destroyed. In no event shall Hitachi be liable for any failure in products or any secondary damage resulting from use at a value exceeding the absolute maximum ratings.

7.6 Derating Design

Continuous high-loaded (high temperature, high voltage, large current) operation should be avoided and derating design should be applied, even within the ranges of the absolute maximum ratings, to ensure reliability.

7.7 Safe Design

Products may experience failures due to accident or unexpected surge voltages. Accordingly, adopt safe design features, such as redundancy or prevention of erroneous action, to avoid extensive damage in the event of a failure.

7.8 Usage

Products are not designed, manufactured, or warranted to be suitable for use where extremely high reliability is required (such as use in nuclear power control, aerospace and aviation, traffic equipment, life-support-related medical equipment, fuel control equipment and various kinds of safety equipment). Inclusion of products in such application shall be fully at the risk of customers.

ECN30108

Hitachi, Ltd. assumes no liability for applications assistance, customer product design, or performance. In such cases it is advised customers to ensure circuit and/or product safeties by using semiconductor devices that assures high reliability or by means of user's fail safe precautions or other arrangement.

(If a semiconductor device fails, there may be cases in which the semiconductor device, wiring or wiring pattern will emit smoke or cause a fire or in which the semiconductor device will burst.)

7.9 Soldering

The peak temperature of flow soldering* must be less than 260°C, and the dip time must be less than 10 seconds. High stress by mounting, such as long time thermal stress by preheating, mechanical stress, etc, can lead to degradation or destruction. Make sure that your mounting method does not cause problem as a system.

* Flow soldering: Only pins enter a solder bath, while the resin or tab does not.

7.10 Others

See "Instructions for Use of Hitachi High-Voltage Monolithic ICs" for other precautions and instructions on how to deal with these kinds of products.

8. Important Notices

- (1) Hitachi warrants performance of its power semiconductor products (hereinafter called "products") to the specifications applicable at the time of sale in accordance with the Product Specification. Testing and other quality control techniques are utilized to the extent Hitachi needs to meet specifications described in the Product Specification. Specific testing of all parameters of each device is not necessarily performed, except those mandated by related laws and/or regulations.
- (2) Should any claim be made within one month of product delivery about products' failure to meet performance described in the Product Specification, all the products in relevant lot(s) shall be re-tested and re-delivered. Products delivered more than one month before of such claim shall not be counted for such response.
- (3) Hitachi assumes no obligation or any way of compensation should any fault about customer's goods using products be found in marketplace. Only in such a case fault of Hitachi is evident and products concerned do not meet the Product Specification, compensation shall be conducted if claimed within one year of product delivery up to in the way of product replacement or payment of equivalent amount.
- (4) Hitachi reserves the right to make changes in the Product Specification and to discontinue mass production of the relevant products without notice. Customers are advised before purchasing to confirm specification of the product of inquiry is the latest version and that the relevant product is on mass production status in such a case purchasing is suspended for one year or more.
- (5) In no event shall Hitachi be liable for any damage that may result from an accident or any other cause during operation of the user's units according to this Product Specification. Hitachi assumes no responsibility for any intellectual property claims or any other problems that may result from applications of information, products or circuits described in this Product Specification.
- (6) No license is granted by this Product Specification under any patents or other rights of any third party or Hitachi, Ltd.
- (7) This Product Specification may not be reproduced or duplicated, in any form, in whole or in part without the written permission of Hitachi, Ltd.
- (8) The products (technologies) described in this Product Specification are not to be provided to any party whose purpose in their application will hinder maintenance of international peace and safety nor are they to be applied to that purpose by their direct purchasers or any third party. When exporting these products (technologies), the necessary procedures are to be taken in accordance with related laws and regulations.

ECN30108

◆Appendix - Supplementary Data

See derating information below when designing with the ECN30108.

1. Safe Operation Area (SOA)

The ECN30108 must not be used outside the SOA shown in FIGURE 1.1, where the current and voltage are at the MU, MV and MW pins (motor coils).

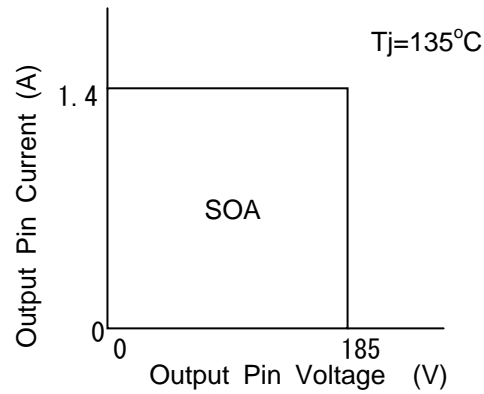

FIGURE 1.1 SOA

2. General Design Derating Standards

- (a) Temperature - Junction operating temperature must be kept under 110°C.
- (b) Supply voltage - VS power supply voltage must be kept under 185V.

ECN30108

3. Dimensions

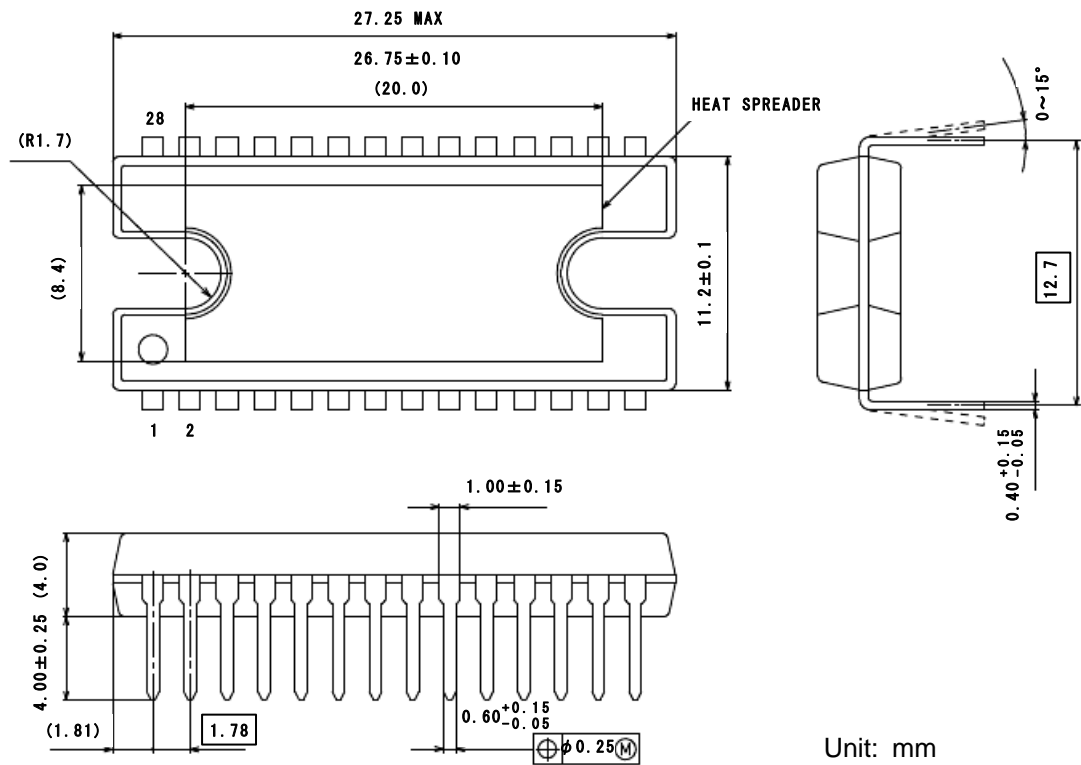

Unit: mm

FIGURE 6.1 Dimensions

Precautions for Safe Use and Notices

If semiconductor devices are handled in inappropriate manner, failures may result. For this reason, be sure to read "Precaution for Use" before use.



This mark indicates an item about which caution is required.



CAUTION

This mark indicates a potentially hazardous situation which, if not avoided, may result in minor or moderate injury and damage to property.



CAUTION

(1) Regardless of changes in external conditions during use "absolute maximum ratings" should never be exceeded in designing electronic circuits that employ semiconductors.

In the case of pulse use, furthermore, "safe operating area (SOA)" precautions should be observed.

(2) Semiconductor devices may experience failures due to accident or unexpected surge voltages. Accordingly, adopt safe design features, such as redundancy or prevention of erroneous action, to avoid extensive damage in the event of a failure.

(3) In cases where extremely high reliability is required (such as use in nuclear power control, aerospace and aviation, traffic equipment, life-support-related medical equipment, fuel control equipment and various kinds of safety equipment), safety should be ensured by using semiconductor devices that feature assured safety or by means of user's fail-safe precautions or other arrangement. Or consult Hitachi's sales department staff.

(If a semiconductor device fails, there may be cases in which the semiconductor device, wiring or wiring pattern will emit smoke or cause a fire or in which the semiconductor device will burst)

NOTICES

1. This Datasheet contains the specifications, characteristics (in figures and tables), dimensions and handling notes concerning power semiconductor products (hereinafter called "products") to aid in the selection of suitable products.
2. The specifications and dimensions, etc. stated in this Datasheet are subject to change without prior notice to improve products characteristics. Before ordering, purchasers are advised to contact Hitachi's sales department for the latest version of this Datasheet and specifications.
3. In no event shall Hitachi be liable for any damage that may result from an accident or any other cause during operation of the user's units according to this Datasheet. Hitachi assumes no responsibility for any intellectual property claims or any other problems that may result from applications of information, products or circuits described in this Datasheet.
4. In no event shall Hitachi be liable for any failure in a semiconductor device or any secondary damage resulting from use at a value exceeding the absolute maximum rating.
5. No license is granted by this Datasheet under any patents or other rights of any third party or Hitachi, Ltd.
6. This Datasheet may not be reproduced or duplicated, in any form, in whole or in part, without the expressed written permission of Hitachi, Ltd.
7. The products (technologies) described in this Datasheet are not to be provided to any party whose purpose in their application will hinder maintenance of international peace and safety nor are they to be applied to that purpose by their direct purchasers or any third party. When exporting these products (technologies), the necessary procedures are to be taken in accordance with related laws and regulations.