

ECN2102/2112

ECN2102 / 2112 is a single chip row driver IC for electroluminescent (EL) display panel.

Functions

- * Low-voltage serial to high-voltage parallel converter
- * 34 outputs of totem pole type

Features

- * Output terminal voltage up to 250V
- * Source / Sink current 500mA

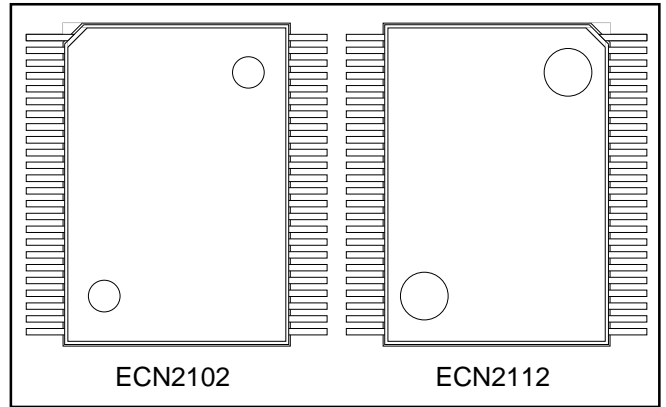
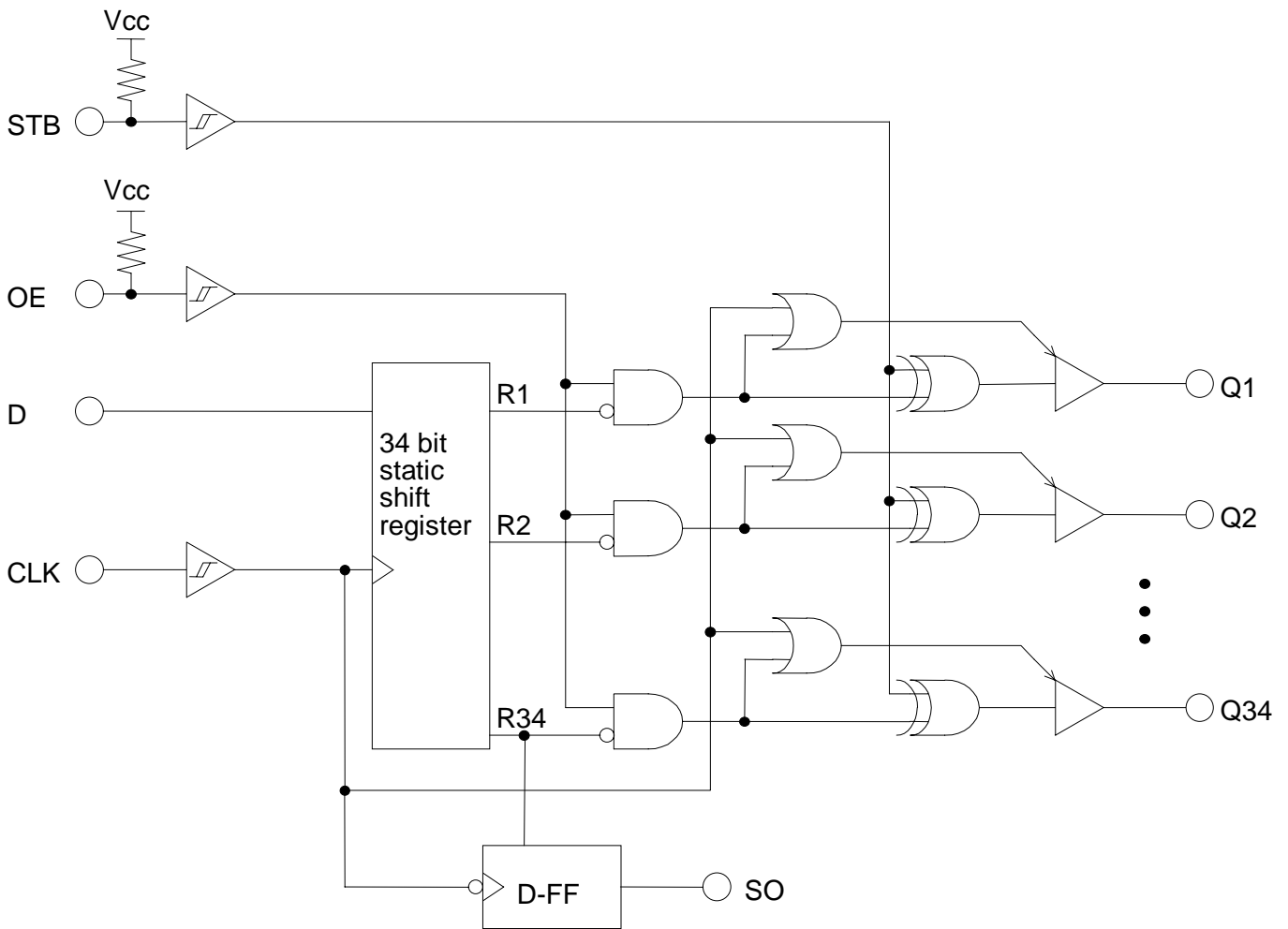

Fig. 1. OUTLINE OF FP-48 PACKAGE



Function Block Diagram (Positive Logic)

ECN2102/2112

1. GENERAL

- (1) TYPE ECN2102/ECN2112
- (2) APPLICATION Row line driver for Electroluminescent (EL) display panel
- (3) STRUCTURE Monolithic IC, processed Dielectric Isolation.
- (4) PACKAGE FP-48 (Fig.1)

2. MAXIMUM ALLOWABLE RATING (Ta=25°C)

No	ITEMS	SYMBOLS	RATINGS	UNITS	CONDITIONS
1	Supply Voltage (logic)	Vcc	-0.5 ~ +7.0	V	to GND terminal
2	Input Voltage (logic)	Vin	-0.5 ~ Vcc+0.5	V	to GND terminal
3	Vs - GND Voltage	VSG	Vcc	V	to GND terminal
4	Output Terminal Voltage	VQ	±250	V	Between Vs, Vcc, GND, Input and Q output
5	Allowable Power Dissipation	PT	800	mW	
6	Operating Temperature	TOP	-40 ~ +85	°C	
7	Storage Temperature	Tstg	-55 ~ +150	°C	

3. RECOMMENDED OPERATING CONDITIONS

No	ITEMS	SYMBOLS	Min.	Typ.	Max.	UNITS	CONDITIONS
1	Supply Voltage (logic)	Vcc	5.0	5.5	6.0	V	
2	Clock Frequency	fCLK	–	–	250	kHz	Vcc= 5.5V Vin= 0V/5.5V
3	Clock Pulse Width	twCLK	80	–	–	ns	
4	Data Setup Time	tsu	80	–	–	ns	
5	Data Hold Time	th	80	–	–	ns	
6	Output Terminal Voltage	VQ	–	±230	–	V	Vcc= 5.5V
7	Peak Output Source Current	HI0H	–	–	-500	mA	Note 1
8	Peak Output Sink Current	HI0L	–	–	+500	mA	Note 1

Note1 : Conduction period ≤ 5 μs per 1 IC

ECN2102/2112

4. ELECTRICAL CHARACTERISTICS (Unless otherwise specified, Ta= 25°C, Vcc= 5.5V, HVCC=230V)

No	ITEMS	SYMBOLS	Min.	Typ.	Max.	UNITS	C O N D I T I O N S	
1	Output Voltage (logic)	VOL	–	–	0.1	V	IOL= 20μA	
		VOH	5.4	–	–	V	IOH=-20μA	
2	Output Current (logic)	IOL	1.0	–	–	mA	VOL= 0.8V	
		IOH	-1.0	–	–	mA	VOLH 4.7V	
3	Input Voltage (logic)	VIL	–	–	1.0	V	D input	
		VIH	3.5	–	–	V		
		VTHL	–	–	0.4	V	CLK,STB input	
		VTLH	4.5	–	–	V		
4	Input Current (logic)	IiH	–	–	10	μA	Vin=5.5V all input/1 input	
		IiL	–	–	-10	μA	Vin=0V D,CLK/1 input	
			–	–	-100	μA	Vin=0V STB/1 input	
5	Dissipation Current(logic)	Istb	–	–	10	μA	No signal all input 5.5V, all output Off	
			–	–	25	mA	No signal, 1ch source output On	
			–	–	5	mA	No signal, 1ch sink output On	
6	Output Voltage	HVOL	–	–	3.0	V	HIOL=1mA	Q out-GND
			–	–	6.0	V	HIOL=200mA	Q out-GND
		HVOH	–	–	4.0	V	HIQH=-1mA	Vs-Q out
			–	–	8.0	V	HIQH=-200mA	Vs-Q out
7	Output SCR dv/dt capability	dv/dt1	200	–	–	V/μs	Vs-Q out,+dv/dt apply.Fig.6	
		dv/dt2	200	–	–	V/μs	Q out-GND,-dv/dt apply.Fig.7	
8	Output SCR Off Period	toff	–	–	6.0	μs	Source side	Fig.8
			–	–	7.0	μs	Sink side	

5. SWITCHING CHARACTERISTICS (Unless otherwise specified, Ta= 25°C, Vcc= 5.5V, Fig.5)

No	ITEMS	SYMBOLS	Min.	Typ.	Max.	UNITS	C O N D I T I O N S	
1	Output Delay Time (logic)	tPLH	–	–	300	ns	CL=15pF	
		tPHL	–	–	300	ns		
2	Output Delay Time	tQLH	–	–	3	μs	RLQ=1kΩ	
		tQHL	–	–	3	μs	CLQ=2000pF	

ECN2102/2112

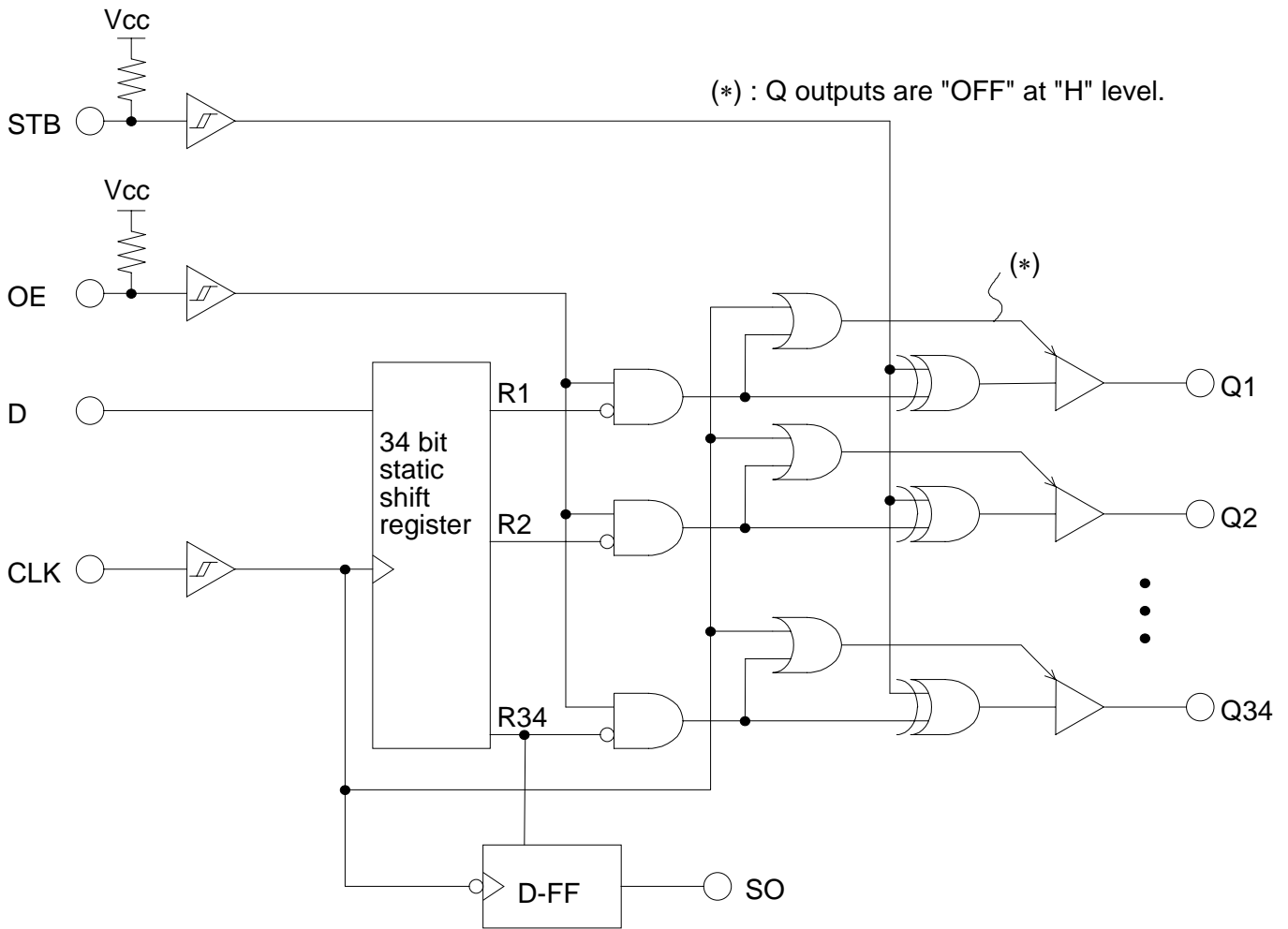

Fig. 2. Function Block Diagram (Positive Logic)

6. FUNCTION TABLE

	CONTROL INPUT				SHIFT REGISTER	OUTPUT	
	CLK	D	OE(*4)	STB	Rn	SO(*1)	Q
SHIFT OPERATION	↑	*	H	*	shift	R34	
	no↑	*	H	*	keep		
OUTPUT OPERATION	L	*	H	H	H		H (*2)
					L		OFF
				L	H		L (*3)
				L	L		OFF
	H	*	H	*	*	ALL OFF	

(*1) 34th data is pushed out as output at the state of down edge↓ of clock signal.

(*2) When shift register is "H", source SCR of Q output is driven to ON.

(*3) When shift register is "H", sink SCR of Q output is driven to ON.

(*4) OE must be kept "H".

ECN2102/2112

7. INPUT / OUTPUT CIRCUIT

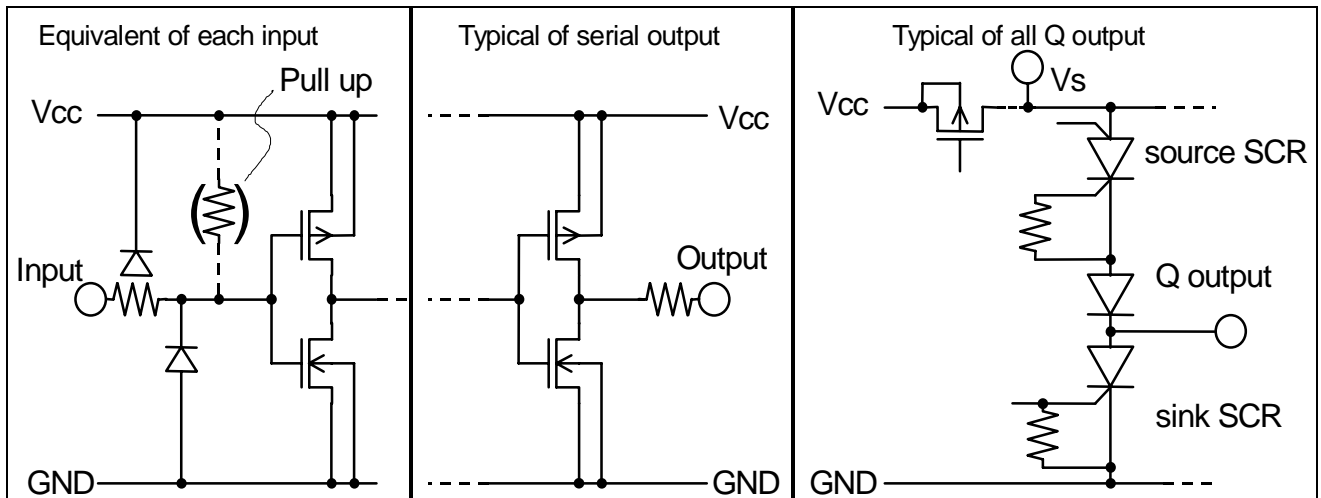

Fig. 3. Input / Output Circuit

ECN2102/2112

8. EXAMPLE OF OPERATING TIMING CHART

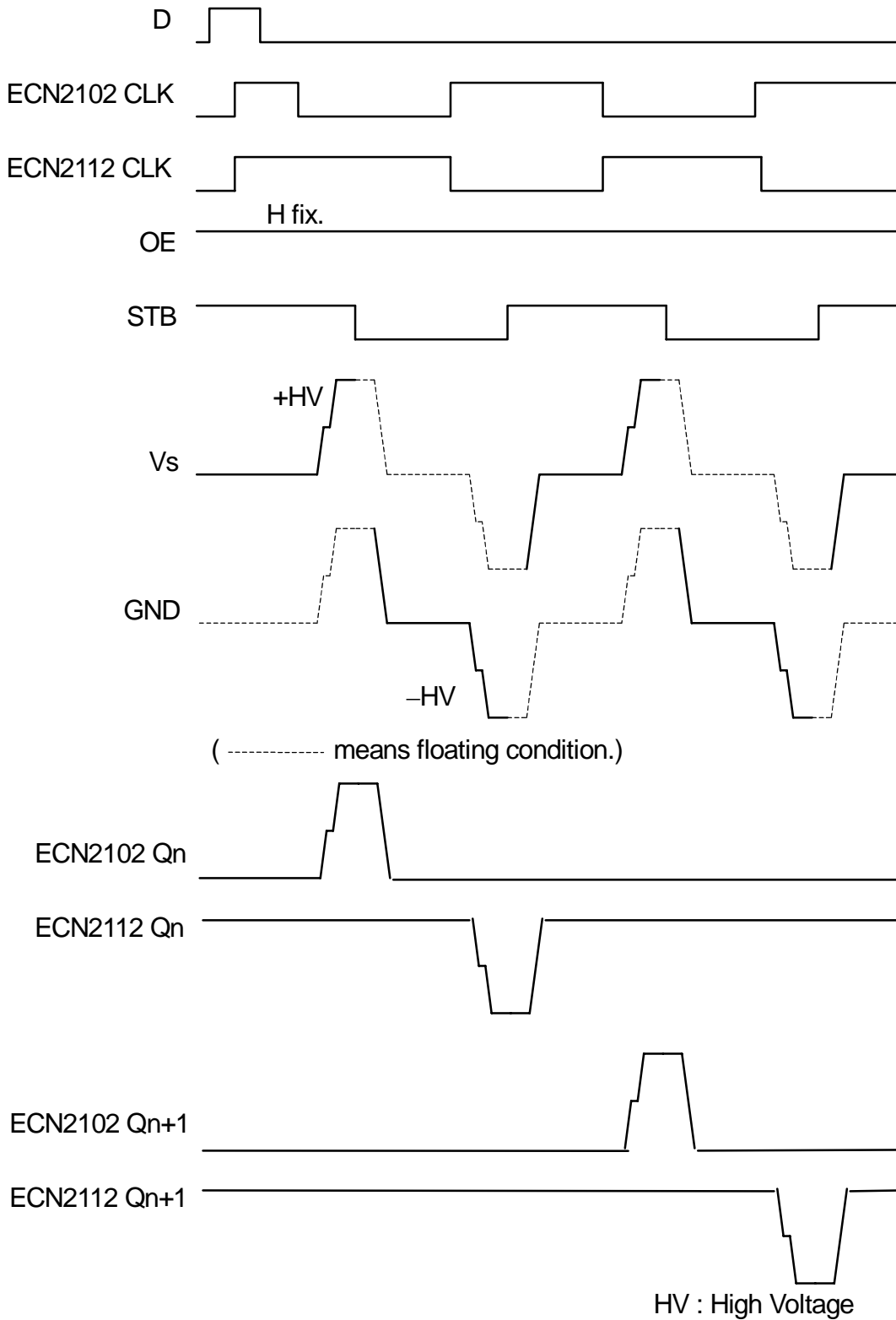
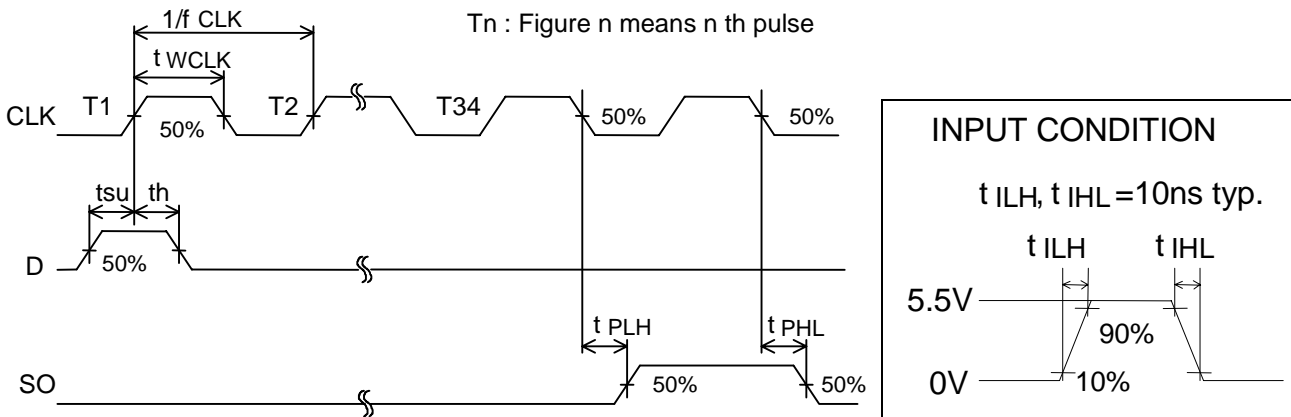

Fig. 4. Example of Operating Timing Chart

ECN2102/2112

9. MEASUREMENT AND MEASUREMENT CIRCUIT



(a) Shift function (SW1→OFF, SW2,3→ON)

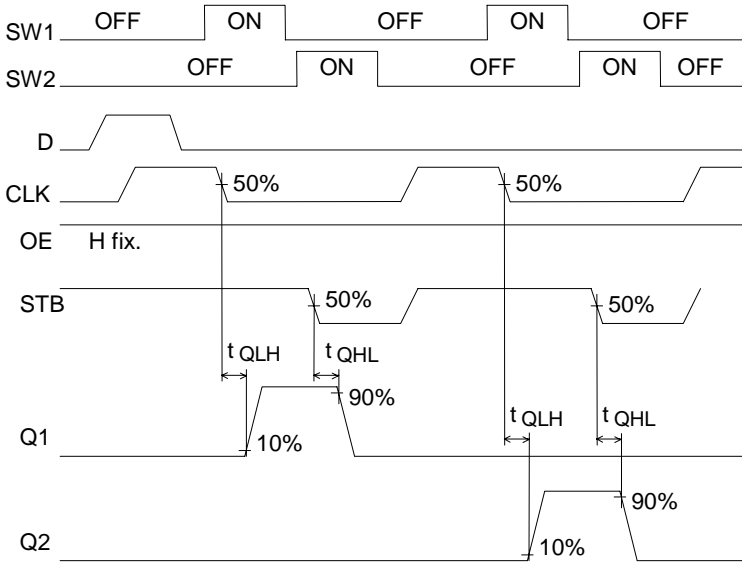

Other Q output

(b) Output Function (SW3→OFF)

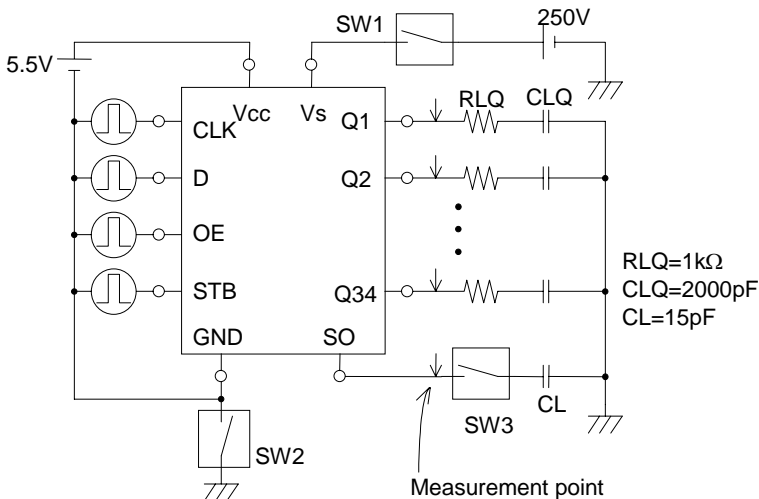

Fig. 5. Switching Characteristics Measurement Circuit

ECN2102/2112

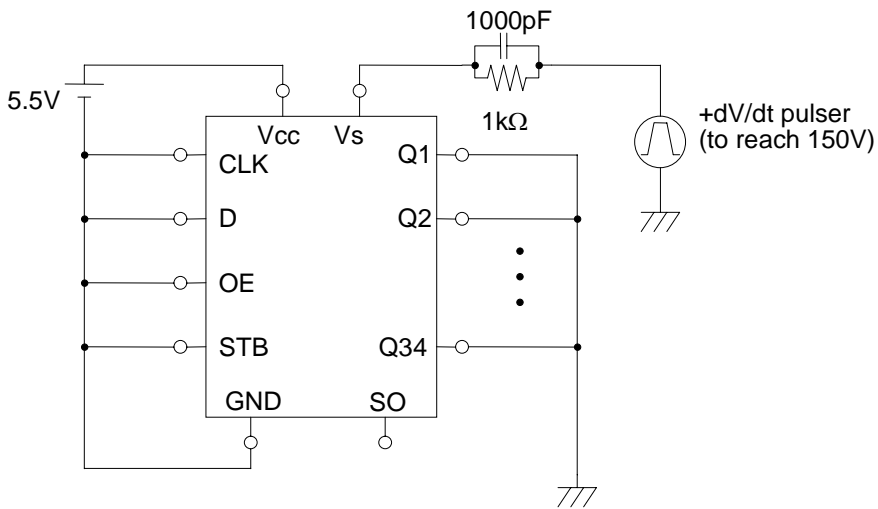

Fig. 6. Output SCR dV/dt capability (dV/dt1) Measurement Circuit

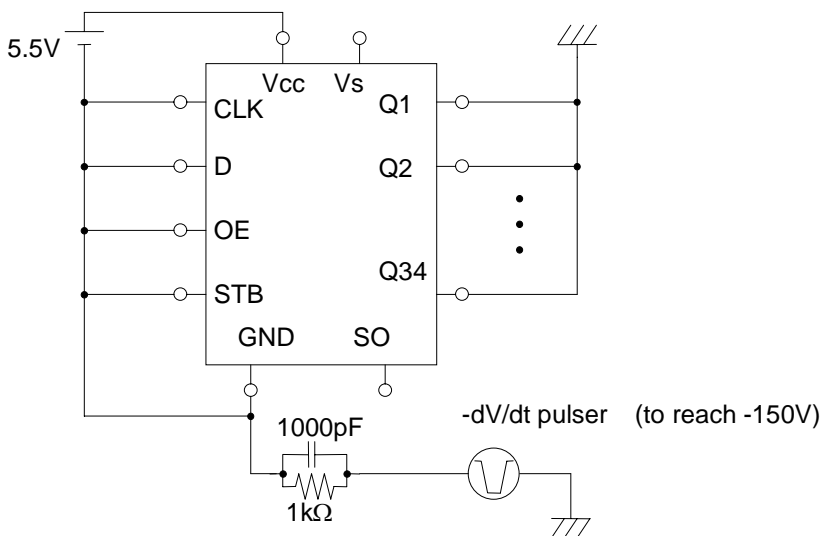
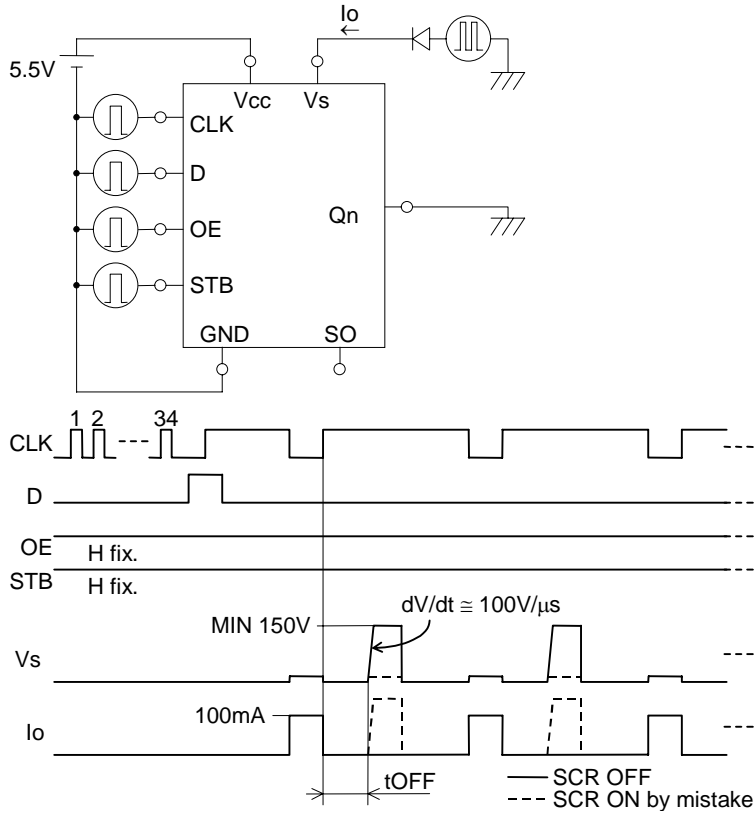
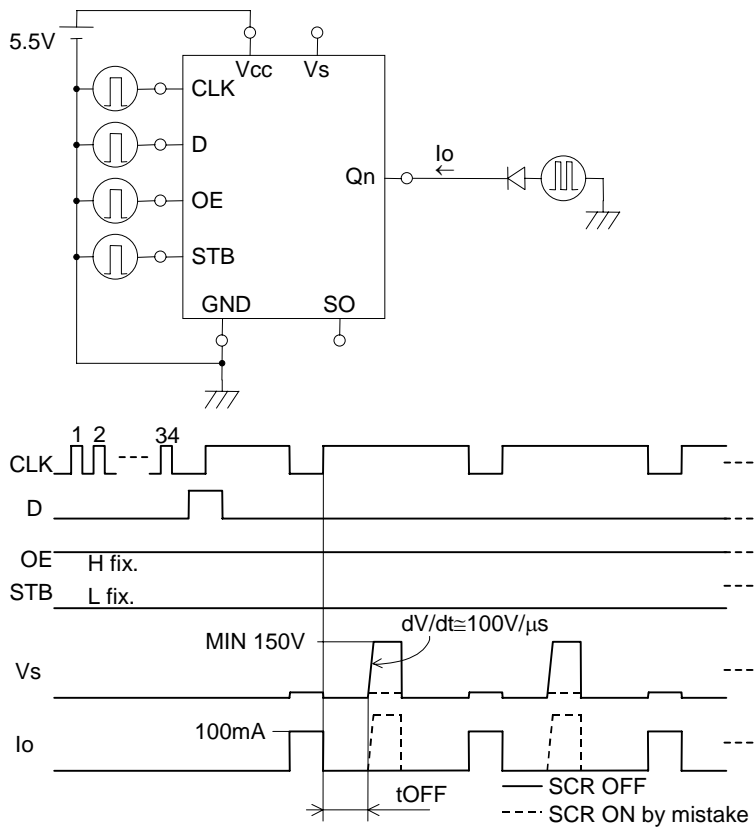

Fig. 7. Output SCR dV/dt capability (dV/dt2) Measurement Circuit

ECN2102/2112



(a) Source SCR



(b) Sink SCR

Fig. 8. Output SCR tOFF Measurement

ECN2102/2112

10. PIN LOCATION

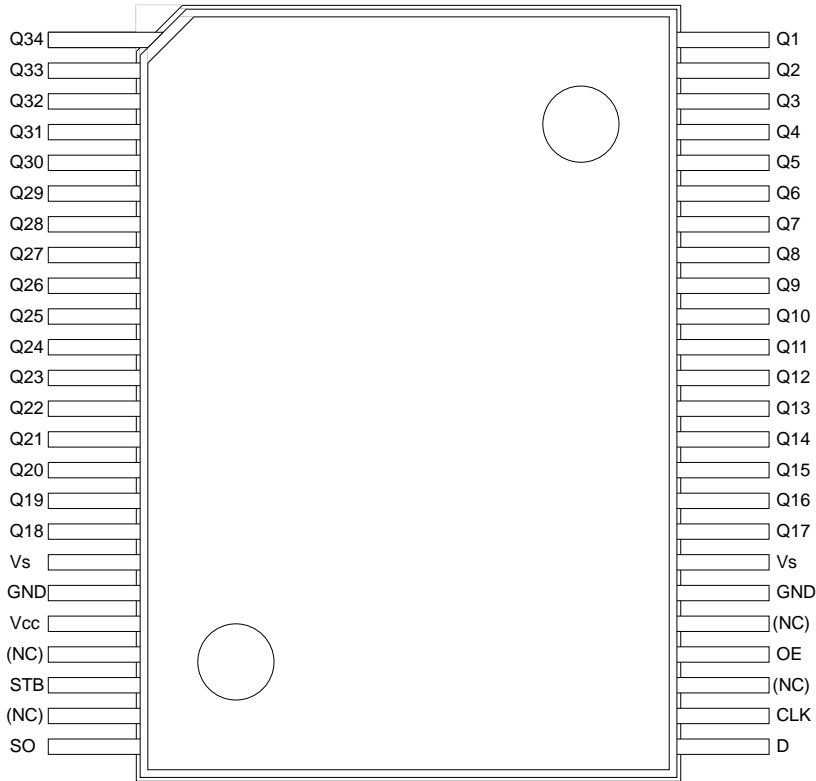

(a) ECN2102

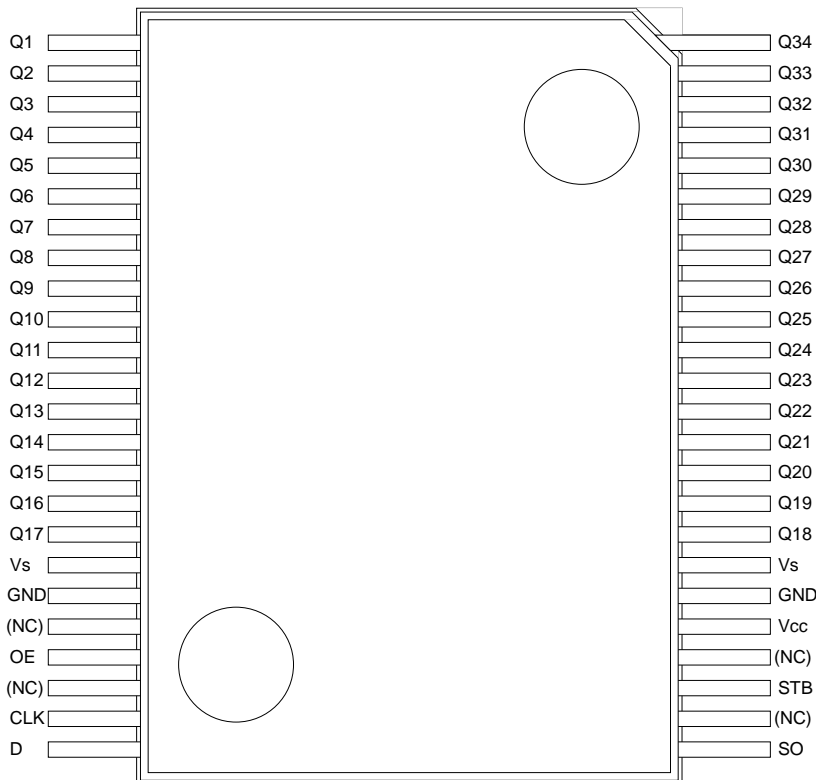

(b) ECN2112

Fig. 9. Pin Location (Top view)

ECN2102/2112

11. PACKAGE OUTLINE

(Unit : mm)

(1) ECN2102

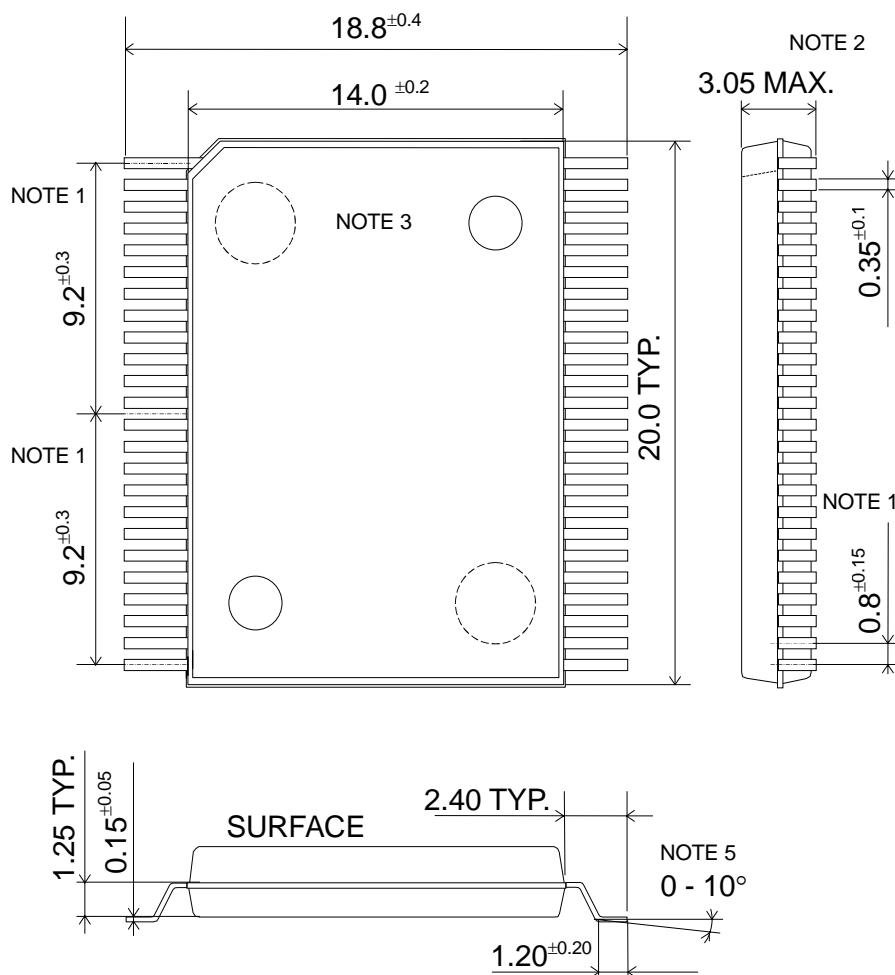

Notes.

1. THIS DIMENSION IS MEASURED AT ROOT OF LEAD. SPACING AT TIP OF LEAD IS MIN 0.2.
2. THIS DIMENSION INCLUDES A WARPAGE OF PACKAGE.
3. MARKING IS ON THE SURFACE OF PACKAGE, INCLUDING HITACHI MARK, TYPE NAME, LOT NUMBER, AND JAPAN MARK.
4. LEADS ARE SOLDER PLATED.
5. THIS IS THE BENDING ANGLE WITH HORIZONTAL PLANE.

Fig. 10. Package outline (ECN2102)

ECN2102/2112

(Unit : mm)

(2) ECN2112

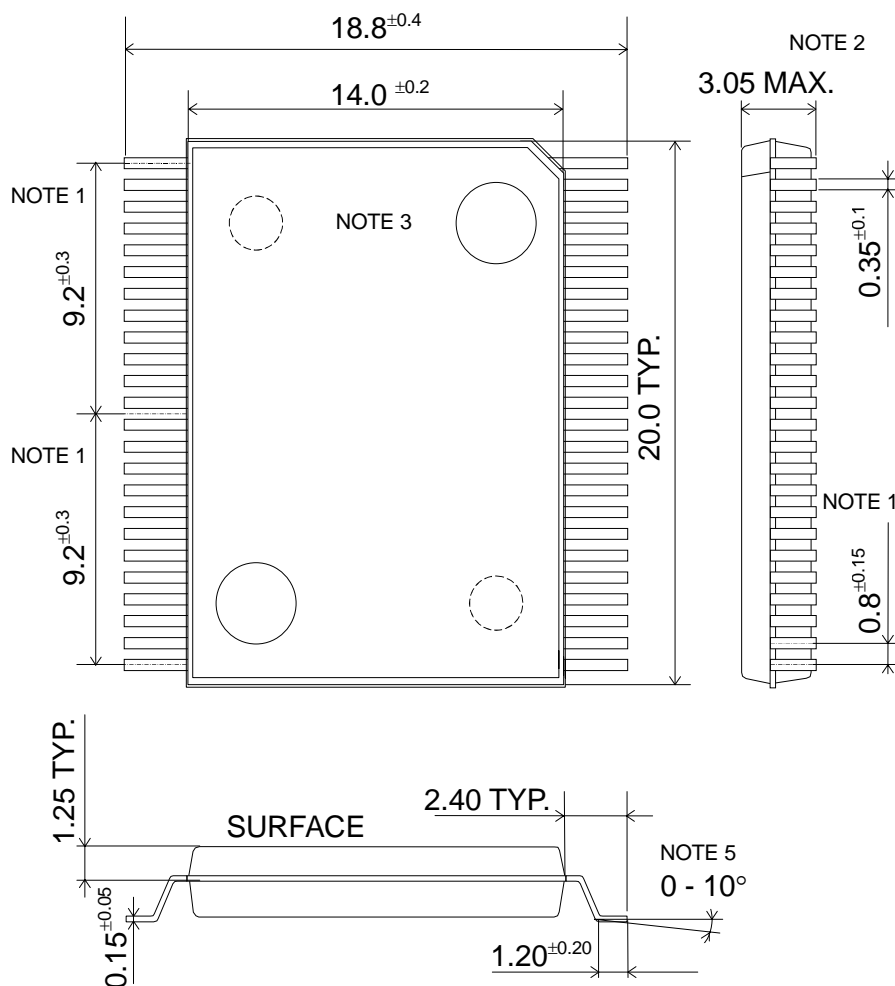

Notes.

1. THIS DIMENSION IS MEASURED AT ROOT OF LEAD. SPACING AT TIP OF LEAD IS MIN 0.2.
2. THIS DIMENSION INCLUDES A WARPAGE OF PACKAGE.
3. MARKING IS ON THE SURFACE OF PACKAGE, INCLUDING HITACHI MARK, TYPE NAME, LOT NUMBER, AND JAPAN MARK.
4. LEADS ARE SOLDER PLATED.
5. THIS IS THE BENDING ANGLE WITH HORIZONTAL PLANE.

Fig. 11. Package outline (ECN2112)

HITACHI POWER SEMICONDUCTORS

Notices

1. The information given herein, including the specifications and dimensions, is subject to change without prior notice to improve product characteristics. Before ordering, purchasers are advised to contact Hitachi sales department for the latest version of this data sheets.
2. Please be sure to read "Precautions for Safe Use and Notices" in the individual brochure before use.
3. In cases where extremely high reliability is required (such as use in nuclear power control, aerospace and aviation, traffic equipment, life-support-related medical equipment, fuel control equipment and various kinds of safety equipment), safety should be ensured by using semiconductor devices that feature assured safety or by means of users' fail-safe precautions or other arrangement. Or consult Hitachi's sales department staff.
4. In no event shall Hitachi be liable for any damages that may result from an accident or any other cause during operation of the user's units according to this data sheets. Hitachi assumes no responsibility for any intellectual property claims or any other problems that may result from applications of information, products or circuits described in this data sheets.
5. In no event shall Hitachi be liable for any failure in a semiconductor device or any secondary damage resulting from use at a value exceeding the absolute maximum rating.
6. No license is granted by this data sheets under any patents or other rights of any third party or Hitachi, Ltd.
7. This data sheets may not be reproduced or duplicated, in any form, in whole or in part , without the expressed written permission of Hitachi, Ltd.
8. The products (technologies) described in this data sheets are not to be provided to any party whose purpose in their application will hinder maintenance of international peace and safety not are they to be applied to that purpose by their direct purchasers or any third party. When exporting these products (technologies), the necessary procedures are to be taken in accordance with related laws and regulations.

- For inquiries relating to the products, please contact nearest overseas representatives which is located "Inquiry" portion on the top page of a home page.

Hitachi power semiconductor home page address <http://www.pi.hitachi.co.jp/pse>

HITACHI