

ECN30611SP/SPR/SPV

The ECN30611 is a 3-phase motor driver IC for permanent magnet synchronous motors and induction motors. The IC integrates IGBTs, FWDs (Free Wheeling Diodes), drive and control circuits, a charge pump, protection circuits, etc. The IC can drive a motor with a high voltage DC power supply (up to 185VDC) directly rectified from AC power line (up to 115VAC) for downsizing a system and reducing power consumption.

Description

- Integrated Charge Pump – Constant TOP Arm bias independent of motor speed.
- Integrated 3-Phase 6-IGBT Motor Bridge with on chip Free-Wheeling diodes.
- Maximum Ratings 250VDC/1.4A.
- Latch-Up free monolithic IC built with a high voltage Dielectrically Isolated (DI) process.
- Available in 3 package types with built-in heat sink (Tab).

Functions and Features

- Power supply sequence is free.
- Vs Operating Voltage Range from 15VDC up to 185VDC.
- IGBTs can be switched at up to 20kHz.
- On-Chip 7.5VDC regulator (CB) with the guaranteed external Max load (25mA).
- Over-Current protection is set by an external Sense Resistor (RS).
- Under-Voltage protection for TOP and BOTTOM IGBT Arms.
- 6 Logic inputs are compatible with 5V CMOS or LSTTL outputs.
- PWM Speed Control is possible with a Micro Controller.

ECN30611SP/SPR/SPV

Block Diagram

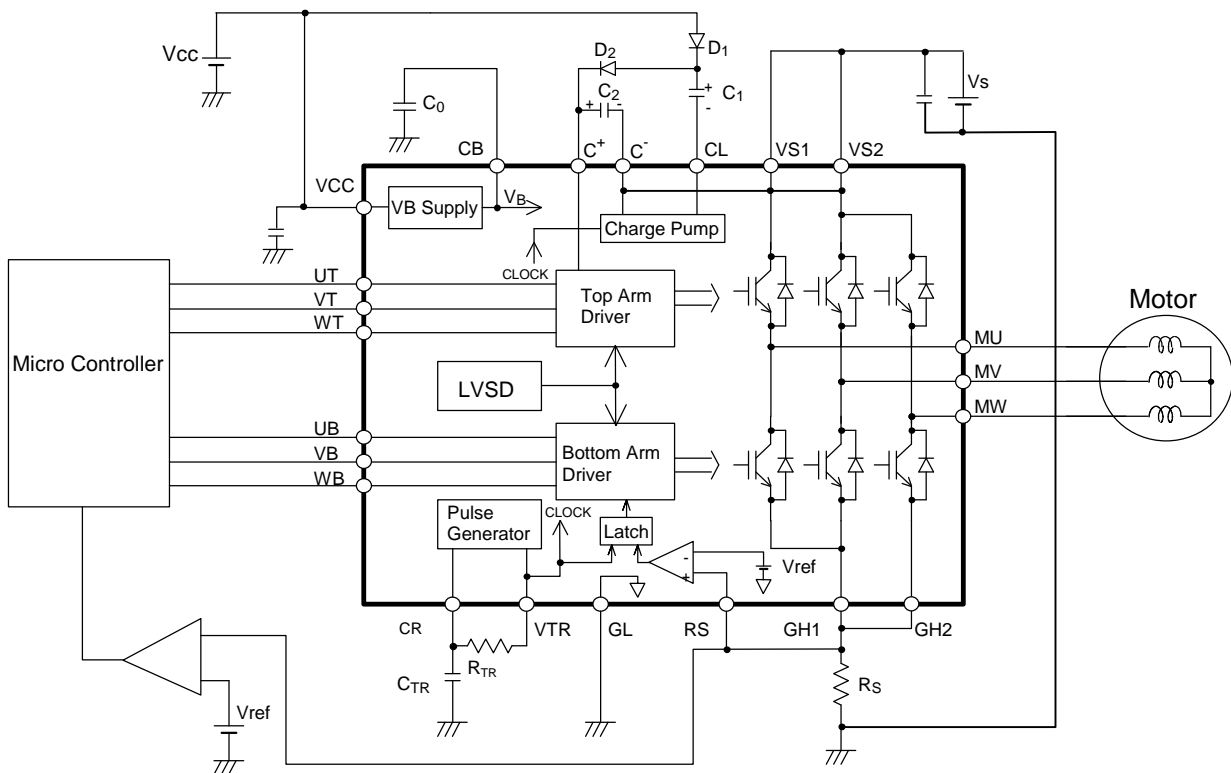

Note; The inside of the bold line shows ECN30611

Figure 1. Block Diagram

Types and Packages

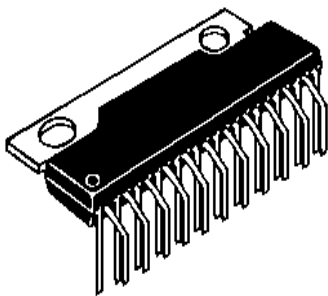

ECN30611SP
(Package Type:SP-23TA)

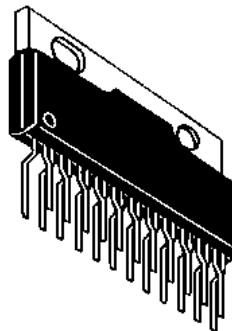

ECN30611SPV
(Package Type:SP-23TB)

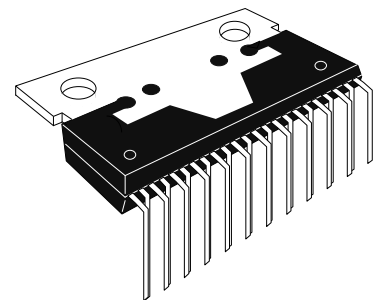

ECN30611SPR
(Package Type:SP-23TR)

ECN30611SP/SPR/SPV

1. Absolute Maximum Ratings

Ta = 25 °C

No.	Item	Symbol	Terminal	Rating	Unit	Condition
1	Output Device Breakdown Voltage	VSM	VS1,VS2 MU,MV,MW	250	V	
2	Analog Supply Voltage	VCC	VCC	18	V	
3	Input Voltage	VIN	VSP,RS HU,HV,HW	-0.5 to VB+0.5	V	
4	Output Current	Pulse	IP MU,MV,MW	1.4	A	Note 1
5		DC		IDC		
6	VB Supply Current	IBMAX	CB	50	mA	
7	Junction Operating Temperature	Tjop	-	-20 to +135	°C	Note 2
8	Storage Temperature	Tstg	-	-40 to +150	°C	

General Note: To determine appropriate deratings for these absolute maximum ratings, see page 12 (the Appendix) paragraphs 1.1 and 1.2.

Note 1: Output IGBTs can handle this peak motor current at up to 25 °C junction operating temperature.

Note 2: Thermal Resistance

- 1) Between junction and IC case (Tab): $R_{jc} = 4 \text{ } ^\circ\text{C} / \text{W}$
- 2) Between junction and air: $R_{ja} = 40 \text{ } ^\circ\text{C} / \text{W}$

Note 3: This IC can withstand 305V within 1 minute.

ECN30611SP/SPR/SPV

2. Electrical Characteristics

Suffix (T ; Top arm, B ; Bottom arm)

Ta = 25°C

No.	Item	Symbol	Terminal	MIN	TYP	MAX	Unit	Condition	
1	Supply Voltage	VSop	VS1,VS2	15	141	185	V		
2		VCCop	VCC	13.5	15	16.5	V		
3	Standby Current	ISH	VS1,VS2	-	0.3	0.5	mA	UT,VT,WT,UB,VB,WB=0V VS=141V, VCC=15V	
4		ICC	VCC	-	3	10	mA	UT,VT,WT,UB,VB,WB=0V VCC=15V,IB=0A	
5	IGBT Collector-Emitter	VONT	MU,MV,MW	-	2.0	3.0	V	I=0.7A,VCC=15V	
6	Saturation Voltage	VONB		-	2.0	3.0	V	I=0.7A,VCC=15V	
7	Output Delay Time	TdONT		0.05	0.5	2.0	μs	VS=141V,VCC=15V	
8		TdONB		0.05	0.5	2.0	μs	I=0.7A	
9	Turn OFF	TdOFFT		0.05	0.5	2.0	μs	Resistive Load	
10		TdOFFB		0.05	0.5	2.0	μs		
11	Free Wheeling Diode	VFDT		-	2.0	2.5	V	I=0.7A	
12	Forward Voltage	VFDB		-	2.0	2.5	V		
13	Reference Voltage	Vref		RS	0.45	0.5	0.55	V	VCC=15V
14	UT,VT, WT	Voltage		VIH	3.5	-	-	V	VCC=15V
15			VIL	UT,VT,WT	-	-	1.5	V	
16	UB,VB, WB Inputs	Current	IIL	-10	-	-	μA	Input=0V VCC=15V	Pull Down Resistor Note 1
17			IIH	-	-	100	μA	Input=5V VCC=15V	
18	VB supply	Voltage	VB	6.8	7.5	8.2	V	VCC=15V,IB=0A	
19	Output	Current	IB	-	-	25	mA	VCC=15V	
20	LVSD	Detect Voltage	LVSDON	VCC,	11.0	12.0	12.9	V	Note 2
21		Recover Voltage	LVSDOFF	MU,MV,	11.1	12.5	13.0	V	
22		Hysteresis	Vrh	MW	0.1	0.5	0.9	V	
23	RS Input Current	IILRS	RS	-100	-	-	μA	VCC=15V, RS=0V	
24	OC Shutdown Delay Time	Tref	RS	-	4.5	6.5	μs	VCC=15V	

Note 1: Internal pull down resistors are typically 200 kΩ. The equivalent circuit is shown in Figure 2.

Note 2: The LVSD (Low Voltage Shut Down) function detects and shuts-down at lower VCC.

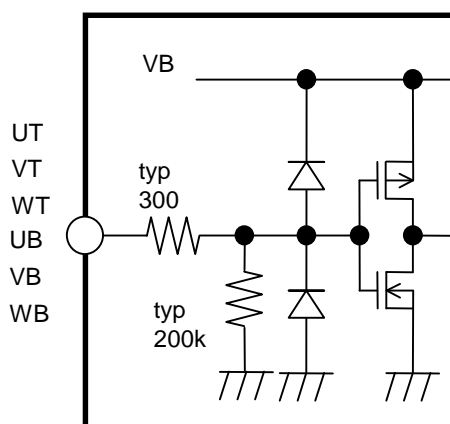

Figure 2. Equivalent circuit around UT,VT,WT,UB,VB,WB

ECN30611SP/SPR/SPV

3. Functions

3.1 Truth Table

Terminal	Input	Output
UT, VT, WT, UB, VB, WB	L	OFF
	H	ON
UT, UB	UT & UB = H	OFF
VT, VB	VT & VB = H	OFF
WT, WB	WT & WB = H	OFF

3.2 Over Current Limit Operation

Over current is detected with the external resistance (Rs). When the RS input voltage exceeds the internal reference voltage (Vref is typically 0.5V), all BOTTOM Arms Turn-OFF. This OFF state is automatically reset once per internal CLOCK period. If not using this function, connect the RS pin to the GL pin.

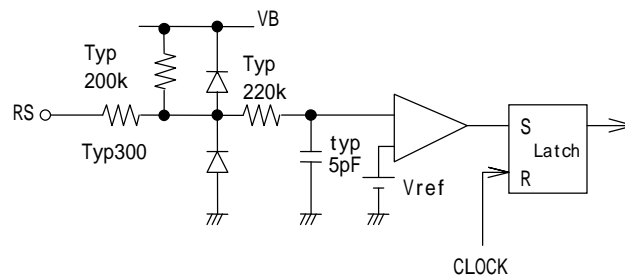

Figure 3. Equivalent circuit around RS

3.3 VCC Under-Voltage Detection

If VCC drops below LVSDON (12.0V typ), all IGBTs (TOP and BOTTOM Arms) Turn-OFF. Normal operation returns when VCC rises above LVSDOFF: the value of LVSDOFF is LVSDON + Vrh.

ECN30611SP/SPR/SPV

4. Standard Applications

4.1 External Components

Component	Standard Value	Usage	Remark
Co	0.22 μ F \pm 20%	Filters the internal power supply (VB)	Stress voltage is VB (=8.2V)
C1,C2	1.0 μ F \pm 20%	For Charge Pump	Stress voltage is VCC
D1,D2	Hitachi DFG1C6 (Glass mold type), DFM1F6 (Resin mold type) or equivalent	For Charge Pump	400V, 1A trr \leq 100ns
Rs	Note 1	Sets Over-Current limit	
CTR	1800 pF \pm 5%	Sets clock frequency	Stress voltage is VB (=8.2V) Note1
RTR	22 k Ω \pm 5%	Sets clock frequency	Stress voltage is VB (=8.2V) Note1

Note 1: The clock frequency is approximated by the following equation:
 Clock Frequency (Hz) \approx 0.494 / (CTR(F) \times RTR(Ω))

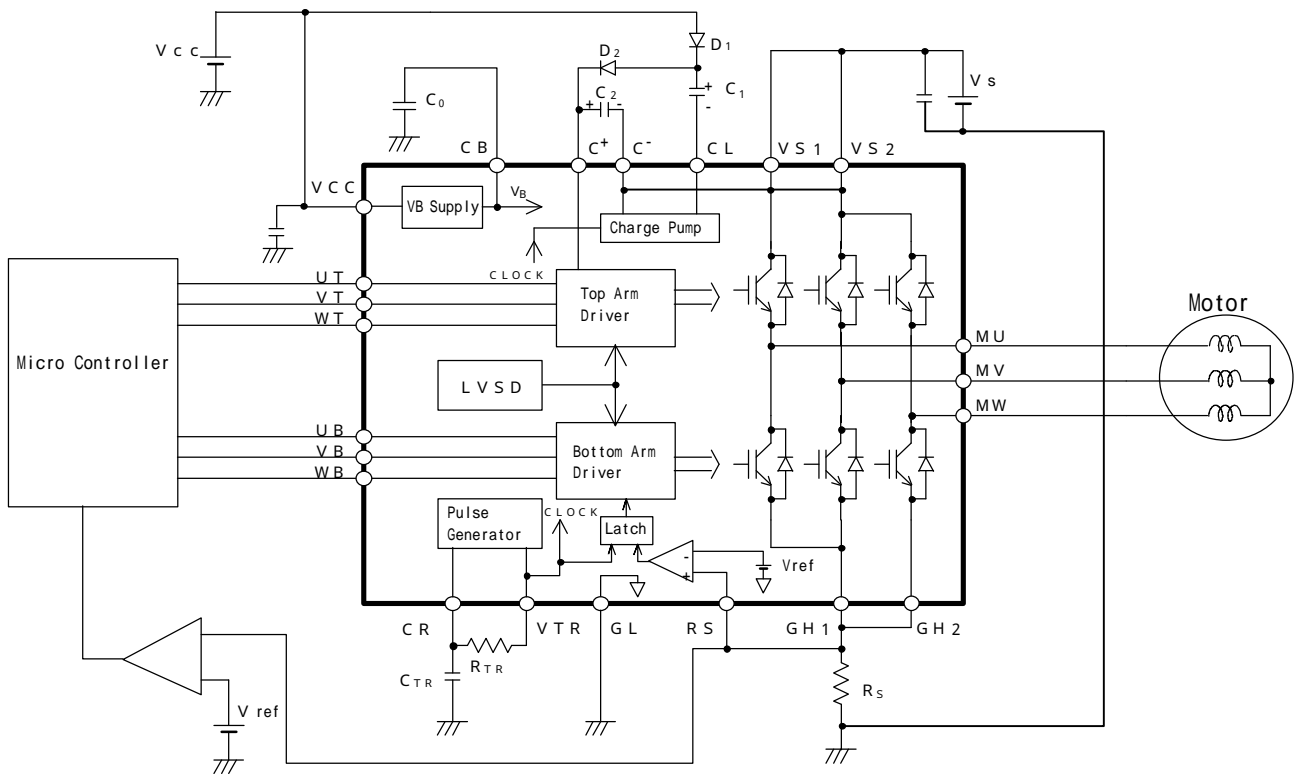

Note; The inside of the bold line shows ECN30611

Figure 4. Block Diagram

4.2 Input Pins (UB, VB, WB, UT, VT, WT)

In some applications, input pins may be sensitive to noise due to high impedance. If noise is detected at an input pin, the following resistor and/or capacitor should be added.

Resistor : 5.6k Ω \pm 5% pull down resistor

Capacitor : 500pF \pm 20% ceramic capacitor close to the input pin

ECN30611SP/SPR/SPV

5. Pinout

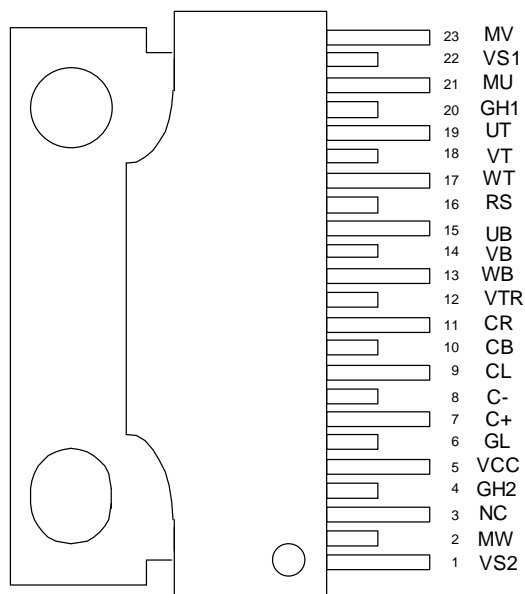

(Marking side)

6. Terminal definitions

Terminal No.	Symbol	Definition	Remark
1	VS2	Power supply for Upper IGBTs of phases V and W	Note1, Note2
2	MW	W phase output (to motor coil W)	Note1
3	NC	No Connection	Note4
4	GH2	W phase emitter of IGBT and anode of FWD.	Note3
5	VCC	Analog/Logic power supply	
6	GL	Analog/Logic ground	
7	C+	For the Charge Pump circuit, power supply for Top Arm drive circuit	Note1
8	C-	For the Charge Pump circuit	Note1, Note2
9	CL	For the Charge Pump circuit	Note1
10	CB	Internally regulated (VB) power supply output	
11	CR	Connect resistance and capacitance to generate the clock frequency	Note5
12	VTR	Connect resistance to generate the clock frequency	Note5
13	WB	Input control signal for bottom arm of phase W	
14	VB	Input control signal for bottom arm of phase V	
15	UB	Input control signal for bottom arm of phase U	
16	RS	Rs voltage input for over current limit operation	
17	WT	Input control signal for top arm of phase W	
18	VT	Input control signal for top arm of phase V	
19	UT	Input control signal for top arm of phase U	
20	GH1	U and V phase emitters of IGBTs and anodes of FWDs.	Note3
21	MU	U phase output (to motor coil U)	Note1
22	VS1	Power supply for Upper IGBT of phase U	Note1, Note2
23	MV	V phase output (to motor coil V)	Note1

Note1: This is high voltage pin.

Note2: The VS1, VS2 and C- pins are connected within the IC. But VS1 and VS2 must be connected with external wiring.

Note3: GH1 and GH2 are not connected within the IC. But these pins must be connected with external wiring.

Note4: Not connected to the internal IC chip.

Note5: See section 4.1.

HITACHI

ECN30611SP/SPR/SPV

7. Inspection

Hundred percent inspection shall be conducted on electric characteristics at room temperature.

8. Cautions

- 8.1 Tightening torque at 0.39 to 0.78 N-m should be applied for device to attach to heat sink.
- 8.2 Tab should not be soldered.
- 8.3 Customers are advised to follow the below cautions to protect semiconductor from electrical static discharge (ESD).
 - a) IC needs to be dealt with caution to protect from damage by ESD. Material of container or any device to carry semiconductor devices should be free from ESD, which may be caused by vibration while transportation. To use electric-conductive container or aluminum sheet is recommended as an effective countermeasure.
 - b) What touches semiconductor devices such as work platform, machine and measuring and test equipment should be grounded.
 - c) Workers should be grounded connecting with high impedance around 100k Ω to 1M Ω while dealing with semiconductor to avoid damaging IC by electric static discharge.
 - d) Friction with other materials such as a high polymer should not be caused.
 - e) Attention is needed so that electric potential will be kept on the same level by short circuit terminals when PC board with mounted IC is carried and that vibration or friction might not occur.
 - f) Air conditioning is needed so that humidity should not drop.
- 8.4 Applying molding or resin coating is recommended for below mentioned pin-to-pin insulation; 1-2, 2-4, 6-7, 8-9, 9-10, 20-21, 21-22, 22-23
- 8.5 Protective function against short circuit (ex. load short, line-to-ground short or top/bottom arm short) is not built in this IC. External protection needs to prevent IC breakdown.
- 8.6 Refer to "Precautions for Use of High-Voltage Monolithic ICs" (No.IC-0401E) for the other precautions and instructions on how to deal with products.
- 8.7 Regardless of changes in external conditions during use, "absolute maximum ratings" should never be exceeded in designing electronic circuits that employ products. In a case absolute maximum ratings are exceeded, products may be damaged or destroyed. In no event shall Hitachi be liable for any failure in products or any secondary damage resulting from use at a value exceeding the absolute maximum ratings.
- 8.8 Products may experience failures due to accident or unexpected surge voltages. Accordingly, adopt safe design features, such as redundancy or prevention of erroneous action, to avoid extensive damage in the event of a failure.
- 8.9 Products are not designed, manufactured, or warranted to be suitable for use where extremely high reliability is required (such as use in nuclear power control, aerospace and aviation, traffic equipment, life-support-related medical equipment, fuel control equipment and various kinds of safety equipment). Inclusion of products in such application shall be fully at the risk of customers.

Hitachi, Ltd. assumes no liability for applications assistance, customer product design, or performance. In such cases it is advised customers to ensure circuit and/or product safety by using semiconductor devices that assures high reliability or by means of user's fail-safe precautions or other arrangement. (If a semiconductor device fails, there may be cases in which the semiconductor device, wiring or wiring pattern will emit smoke or cause a fire or in which the semiconductor device will burst.)

ECN30611SP/SPR/SPV

- 8.10 Lead (Pb)-free solder is used for coating pins and the tab of this IC. In case of flow soldering*, the IC can withstand peak temperature 260oC for less than 10 seconds in liquid solder. *Only pins are in liquid solder. The package body and the tab must not be in it.

9. Important Notices

- 9.1 Hitachi warrants performance of its power semiconductor products (hereinafter called "products") to the specifications applicable at the time of sale in accordance with the Product Specification.

Testing and other quality control techniques are utilized to the extent Hitachi needs to meet specifications described in the Product Specification. Specific testing of all parameters of each device is not necessarily performed, except those mandated by related laws and/or regulations.

- 9.2 Should any claim be made within one month of product delivery about products' failure to meet performance described in the Product Specification, all the products in relevant lot(s) shall be re-tested and re-delivered. Products delivered more than one month before of such claim shall not be counted for such response.

- 9.3 Hitachi assumes no obligation or any way of compensation should any fault about customer's goods using products be found in marketplace. Only in such a case fault of Hitachi is evident and products concerned do not meet the Product Specification, compensation shall be conducted if claimed within one year of product delivery up to in the way of product replacement or payment of equivalent amount.

- 9.4 Hitachi reserves the right to make changes in the Product Specification and to discontinue mass production of the relevant products without notice. Customers are advised before purchasing to confirm specification of the product of inquiry is the latest version and that the relevant product is on mass production status in such a case purchasing is suspended for one year or more.

- 9.5 In no event shall Hitachi be liable for any damage that may result from an accident or any other cause during operation of the user's units according to this Product Specification. Hitachi assumes no responsibility for any intellectual property claims or any other problems that may result from applications of information, products or circuits described in this Product Specification.

- 9.6 No license is granted by this Product Specification under any patents or other rights of any third party or Hitachi, Ltd.

- 9.7 This Product Specification may not be reproduced or duplicated, in any form, in whole or in part, without the expressed written permission of Hitachi, Ltd.

- 9.8 The products (technologies) described in this Product Specification are not to be provided to any party whose purpose in their application will hinder maintenance of international peace and safety nor are they to be applied to that purpose by their direct purchasers or any third party. When exporting these products (technologies), the necessary procedures are to be taken in Accordance with related laws and regulations.

ECN30611SP/SPR/SPV

Appendix - Supplementary Reference Data

Refer to the derating information below when designing with the ECN30611.

1. Safe Operation Area (SOA) and Derating Standards

1.1 SOA

The ECN30611 must not be used outside the SOA shown in Figure 5, where the current and voltage are at the MU, MV and MW pins (motor coils) .

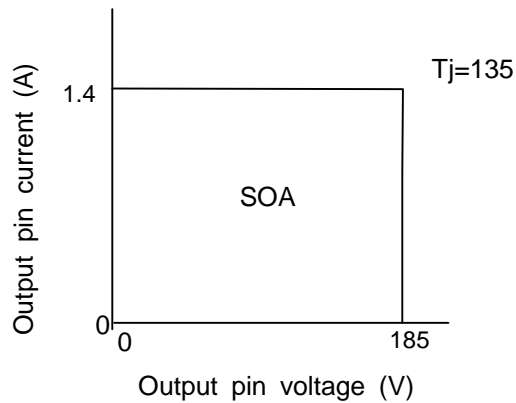

Figure 5. SOA

1.2 General Design Derating Standards

- a) Temperature - Junction Operating Temperature must be kept under 110 °C.
- b) Supply Voltage - VS power supply voltage must be kept under 185 V.

ECN30611SP/SPR/SPV

2. Package Dimensions (Unit: mm)

(1) ECN30611SP (SP-23TA)

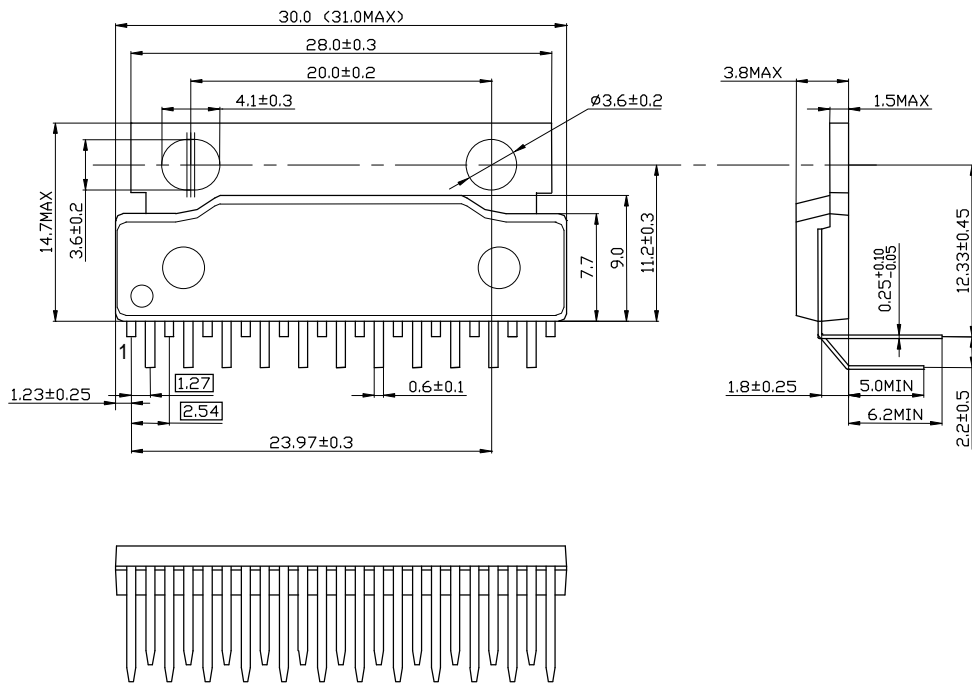

(2) ECN30611SPV (SP-23TB)

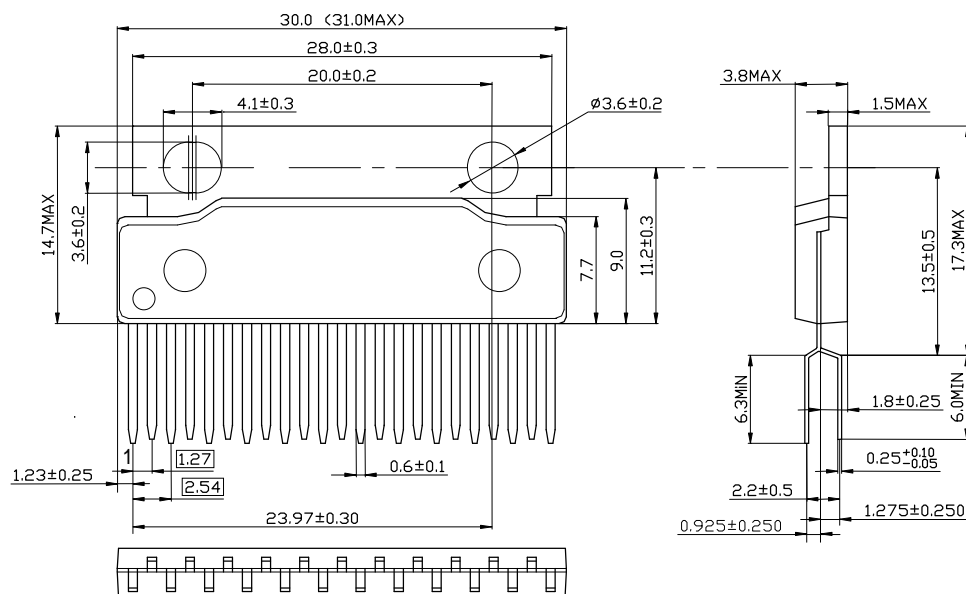

ECN30611SP/SPR/SPV

(3) ECN30611SPR (SP-23TR)

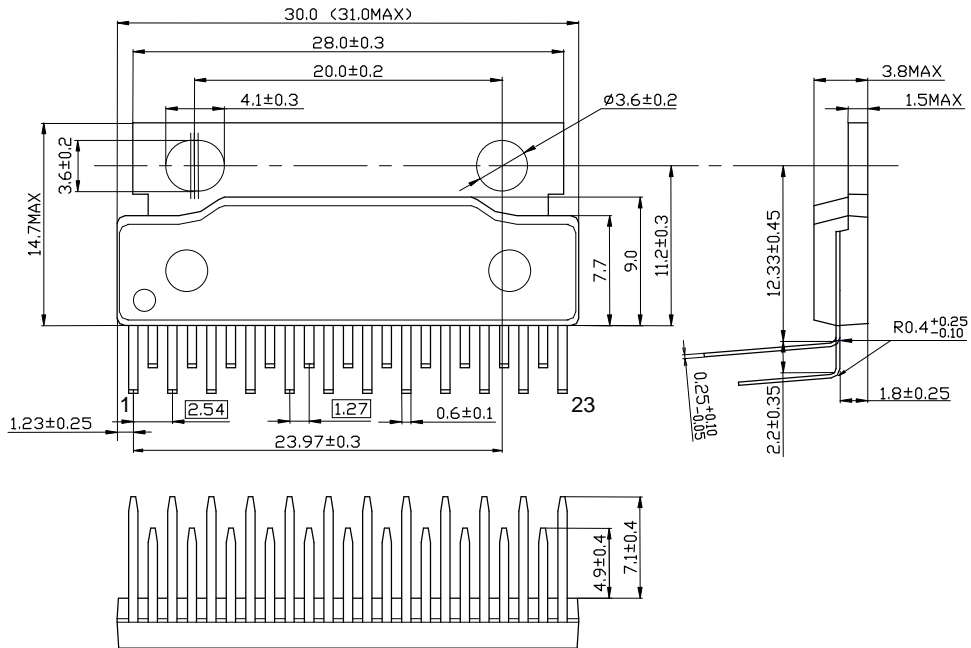

Precautions for Safe Use and Notices

If semiconductor devices are handled in inappropriate manner, failures may result. For this reason, be sure to read "Precaution for Use" before use.



This mark indicates an item about which caution is required.



CAUTION

This mark indicates a potentially hazardous situation which, if not avoided, may result in minor or moderate injury and damage to property.



CAUTION

- (1) Regardless of changes in external conditions during use "absolute maximum ratings" should never be exceeded in designing electronic circuits that employ semiconductors. In the case of pulse use, furthermore, "safe operating area (SOA)" precautions should be observed.
- (2) Semiconductor devices may experience failures due to accident or unexpected surge voltages. Accordingly, adopt safe design features, such as redundancy or prevention of erroneous action, to avoid extensive damage in the event of a failure.
- (3) In cases where extremely high reliability is required (such as use in nuclear power control, aerospace and aviation, traffic equipment, life-support-related medical equipment, fuel control equipment and various kinds of safety equipment), safety should be ensured by using semiconductor devices that feature assured safety or by means of user's fail-safe precautions or other arrangement. Or consult Hitachi's sales department staff.

(If a semiconductor device fails, there may be cases in which the semiconductor device, wiring or wiring pattern will emit smoke or cause a fire or in which the semiconductor device will burst)

NOTICES

1. This Data Sheet contains the specifications, characteristics (in figures and tables), dimensions and handling notes concerning power semiconductor products (hereinafter called "products") to aid in the selection of suitable products.
2. The specifications and dimensions, etc. stated in this Data Sheet are subject to change without prior notice to improve products characteristics. Before ordering, purchasers are advised to contact Hitachi's sales department for the latest version of this Data Sheet and specifications.
3. In no event shall Hitachi be liable for any damage that may result from an accident or any other cause during operation of the user's units according to this Data Sheet. Hitachi assumes to responsibility for any intellectual property claims or any other problems that may result from applications of information, products or circuits described in this Data Sheet.
4. In no event shall Hitachi be liable for any failure in a semiconductor device or any secondary damage resulting from use at a value exceeding the absolute maximum rating.
5. No license is granted by this Data Sheet under any patents or other rights of any third party or Hitachi, Ltd.
6. This Data Sheet may not be reproduced or duplicated, in any form, in whole or in part, without the expressed written permission of Hitachi, Ltd.
7. The products (technologies) described in this Data Sheet are not to be provided to any party whose purpose in their application will hinder maintenance of international peace and safety nor are they to be applied to that purpose by their direct purchasers or any third party. When exporting these products (technologies), the necessary procedures are to be taken in accordance with related laws and regulations.